



**M45939B**

45939; Honda GX160,  
20-Gallon Tank

## **Gasoline Portable Air Compressor Installation, Operation and Maintenance Manual**

*To the Owner:*

Thank you for purchasing a NorthStar Air Compressor. Your machine is designed for long life, dependability, and the top performance you demand! Please take time now to read through this manual so you better understand the machine's operation, maintenance and safety precautions. Everyone who operates this machine must read and understand this manual. The time you take now will prolong your machine's life and prepare you for its safe operation. Enjoy the exceptional performance of your NorthStar Air Compressor, the industry leader! The manufacturer reserves the right to make improvements in design and/or changes in specifications at any time without incurring any obligation to install them on units previously sold.

### **Quick Facts**

Engine Oil	Engine is shipped without oil. Fill before starting. Use SAE 10W-30 motor oil.	
Pump Oil	Check pump oil level before starting. Use non-detergent pump oil (part # 4043).	
Air Filter	Replacement air filter part number is AB2281000	
Maximum Pressure	Maximum pressure = 130 psi.	
Maintenance Schedule	Engine:	Oil: change after first 20 hours, then annually or every 100 hours. Spark Plug: clean every 100 hrs, replace annually or every 300 hrs. Air Filter: clean weekly, replace annually or every 1000 hrs. Refer to your Honda engine owner's manual for further instructions.
	Tank:	Drain water daily
	Compressor Pump:	Oil: change after first 50 hours, then every 3 months or 500 hours.

**Read and understand all manuals before operating.**

**Any Questions, Comments, Problems, or Parts Orders**  
**Call NorthStar Product Support 1-800-270-0810**

## Table of Contents

Important Safety Instructions	2	Maintenance	6
Receipt and Inspection	2	Kits & Service Parts	6
Machine Component Identification	3	Exploded View / Component List	7-8
Assembly	4	Pneumatic Schematic Diagrams	9
Operation	5	Troubleshooting	10
		Limited Warranty	11

## Safety

### DEFINITIONS

#### DANGER!

WILL cause DEATH, SEVERE INJURY or substantial property damage.

#### WARNING!

CAN cause DEATH, SEVERE INJURY or substantial property damage.

#### CAUTION!

WILL or CAN cause MINOR INJURY or property damage.

### GENERAL SAFETY PRECAUTIONS

**ALWAYS** wear eye protection when operating or servicing compressor.

**NEVER** operate where flammable or explosive liquids or vapors such as gasoline, natural gas and solvents are present.

**NEVER** remove, paint over, or deface decals. Replace any missing decals.

**NEVER** operate with guards or shields removed, damaged or broken.

**NEVER** operate indoors, this compressor intended for outdoor use only. Avoid inhaling exhaust fumes, risk of asphyxiation. Exhaust fumes are deadly.

**NEVER** add fuel when the product is operating or hot.

**NEVER** directly inhale compressed air.

**NEVER** over-pressurize the receiver tank or similar vessels beyond design limits.

**NEVER** use a receiver tank or similar vessels that fail to meet the design requirements of the compressor.

**NEVER** drill into, weld or otherwise alter the receiver tank or similar vessels.

**NEVER** remove, adjust, bypass, change, modify or make substitutions for safety/relief valves, pressure switches or other pressure control related devices.

**NEVER** use air tools or attachments without first determining the maximum pressure recommended for that equipment.

**NEVER** point air nozzles or sprayers toward people or animals.

**NEVER** touch the compressor pump, engine or discharge tubing during or shortly after operation. These parts become hot.

### BREATHING AIR PRECAUTION

NorthStar air compressors are not designed, intended or approved for breathing air. Compressed air should not be used for breathing air applications unless treated in accordance with all applicable codes and regulations.

## Receipt and Inspection

Before signing the delivery receipt, inspect for damage and missing parts. If damage or missing parts are apparent, make the appropriate notation on the delivery receipt, then sign the receipt. Immediately contact the carrier for an inspection. All material must be held in the receiving location for the carrier's inspection. Delivery receipts that have been signed without a notation of damage or missing parts are considered to be delivered "clear" Subsequent claims are then considered to be concealed damage claims. Settle damage claims directly with the transportation company.

If you discover damage after receiving the air compressor (concealed damage), the carrier must be notified within 15 day of receipt and an inspection must be requested by telephone with confirmation in writing. On concealed damage claims, the burden of establishing that the compressor was damaged in transit reverts back to the claimant.

Read the compressor nameplate to verify it is the model ordered, and read the motor nameplate to verify it is compatible with your electrical conditions. Make sure electrical enclosures and components are appropriate.

# Machine Component Identification

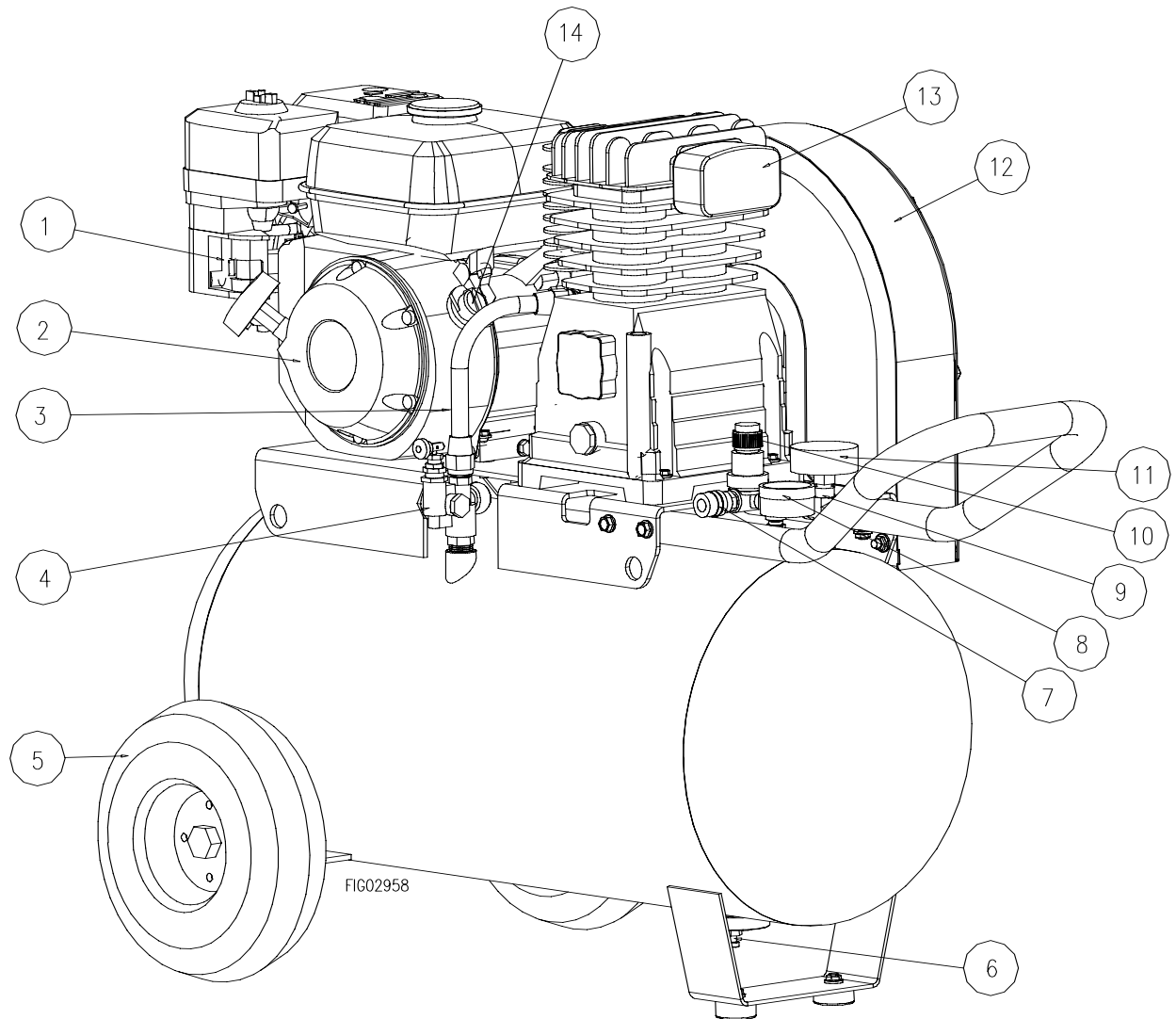

1. **Engine Control** - Location of choke, engine speed and fuel valve.
2. **Engine** - Engine is NOT shipped with oil. Refer to engine owners' manual for proper viscosity and capacity of oil for your engine.
3. **Discharge Tube** - This tube carries compressed air from the pump to the check valve. This tube becomes very hot during use. To avoid the risk of severe burns, never touch the discharge tube.
4. **Unloader** - Lift knob to relieve pressure when starting the engine.
5. **Pneumatic Tires** - Keep tire pressure at 20 psi for easy movement.
6. **Tank Drain** - Location of tank drains. Drain tank daily or after each use.
7. **Quick Connect** - This is a 1/4" quick connect.
8. **Regulated Pressure Gauge** - Easy to read liquid filled gauge indicates regulated pressure.
9. **ASME Safety Valve** - This valve automatically releases air if the tank pressure exceeds the preset maximum.
10. **Regulator** - Adjust outlet pressure, not to exceed pressure rating of the tool.
11. **Tank Pressure Gauge** - Easy to read liquid filled gauge indicates pressure in the tank.
12. **Belt Guard** - Covers the belt, motor pulley and flywheel. **NEVER** operate compressor without belt guard.
13. **Compressor Air Filter** - Make sure your air filter is clean and particle free. See pump exploded view for replacement filter part number.
14. **On/Off Switch** - Make sure switch is at "ON" position when starting engine.

# Assembly

Assemble tires on air compressor as shown. Allow 1/16" movement between hex nut and wheel.

Item #	Description	Qty.
82240	3/4" x 3-3/4" Bolt	2
82040	3/4" Hex Nut	2

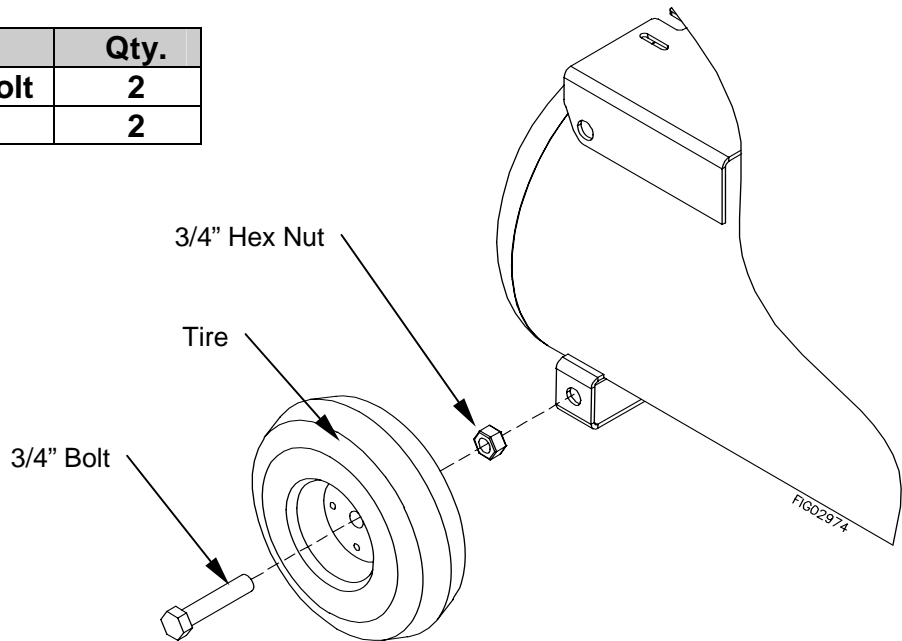

Attach handle and rubber feet as shown.

Item #	Description	Qty.
82018	5/16" x 2" Flange Bolt	4
82019	5/16" Flange Nut	6
82015	5/16" x 3/4" Flange Bolt	2

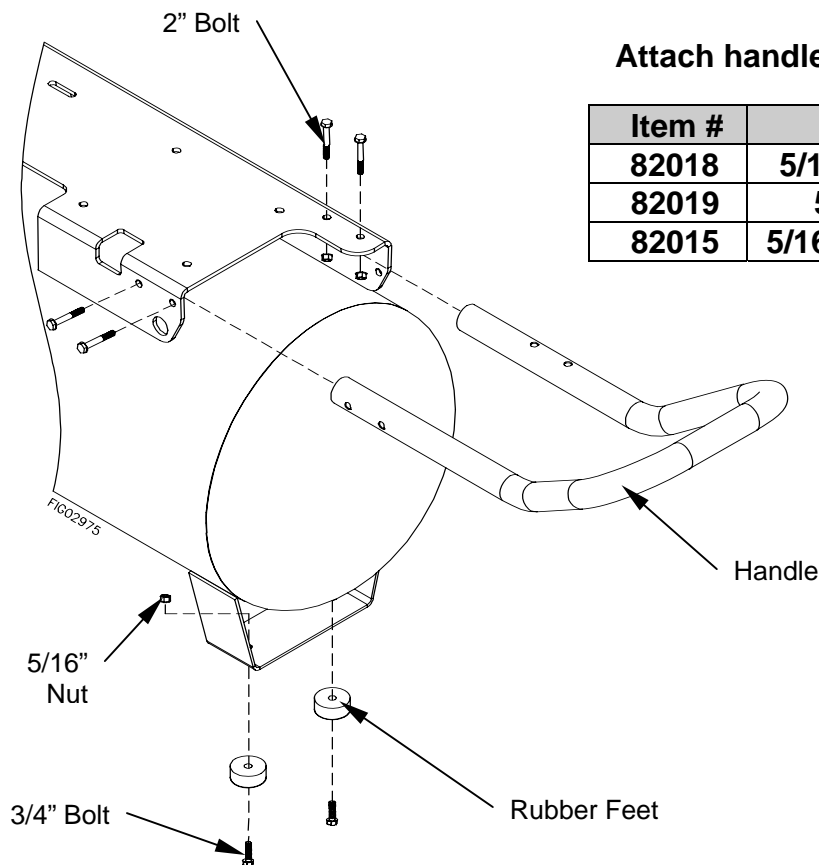

# Operation

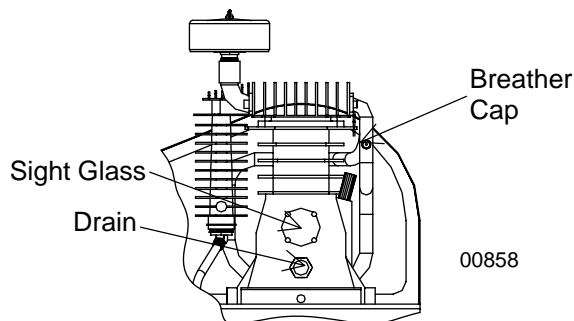

## INITIAL START-UP

1. Pump is shipped with oil. Remove the oil cap and check pump oil level. Add SAE 30 non-detergent pump oil (NorthStar part #4043), if necessary. Hand tighten breather cap.

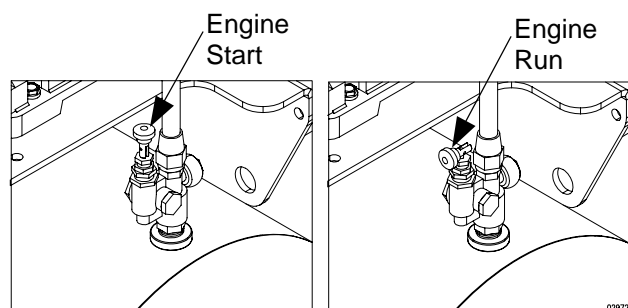

2. Turn pressure relief knob to engine start position.
3. The engine is shipped without oil. Refer to the engine manual for oil capacity and viscosity recommendations.
4. Refer to engine manual to start your engine.
5. Once the engine has started, move the pressure relief knob to the engine run position.

**CAUTION!** Unusual noise or vibration indicates a problem. Do not continue to operate until you identify and correct the source of the problem.

**CAUTION!** Do not attach air tools to open end of the hose until start-up is completed and the unit checks out OK.

6. Run the unit for 30 minutes, with ball valve open, to break in pump parts.
7. Close the ball valve to shut off airflow. The compressor is now ready for use.
8. After 50 hours of operation change the compressor oil.

## WARNING!

Never disconnect threaded joints with pressure in the tank.

**NOTE:** Reduce tank pressure below 10 psi, then drain moisture from tank daily to avoid tank corrosion. Drain moisture from tank(s) by opening the drain petcock located at the bottom of the tank.

## COMPRESSOR LUBRICATION

**CAUTION!** Do not operate without lubricant or with inadequate lubricant. Use of compressor without lubricant or inadequate lubricant voids all warranties.

### Synthetic Lubricants

Synthetic lubricants are recommended after 50-hour break-in. Compressor life is greatly increased with the use of synthetic lubricants. **CAUTION!** If you will be using synthetic lubricant, all downstream piping material and system components must be compatible.

**Suitable** Viton®, Teflon®, Epoxy (Glass Filled), Oil Resistant Alkyd, Fluorosilicone, Fluorocarbon, Polysulfide, 2-Component Urethane, Nylon, Delrin®, Celcon®, High Nitrile Rubber (Buna N. NBR more than 36 Acrylonite), Polyurethane, Polyethylene, Epichlorohydrin, Polyacrylate, Melamine, Polypropylene, Baked Phenolics, Epoxy, Modified Alkyds

(® indicates trademark of DuPont Corporation)

### Not Recommended

Neoprene, Natural Rubber, SBR Rubber, Acrylic Paint, Lacquer, Varnish, Polystyrene, PVC, ABS, Polycarbonate, Cellulose Acetate, Latex, EPR, Acrylics, Phenoxy, Polysulfones, Styrene Acrylonitrile (San), Butyl

**Alternate Lubricants.** You may use petroleum-based lubricant that is premium quality, does not contain detergents, contains only anti-rust, anti-oxidation, and anti-foam agents as additives, has a flashpoint of 440°F (227°C) or higher, and has a auto-ignition point of 650°F (343°C) or higher.

See the petroleum lubricant viscosity table below. The table is intended as a general guide only. Heavy-duty operating conditions require heavier viscosities. Refer specific operating conditions to NorthStar Product Support at 1-800-270-0810.

Temperature around Compressor	Viscosity Grade	
	ISO	SAE
Below 40°F (4°C)	60	20
40°F to 80°F (4°C to 27°C)	100	30
80°F to 100°F (27°C to 37°C)	150	40

### Pump Capacities.

Refer to the following table for crankcase capacity

Item #	Crankcase capacity
45939	36 oz

# Maintenance

**WARNING!** Disconnect spark plug wire from spark plug and release air pressure from system before performing maintenance.

**NOTE:** All compressed air systems contain maintenance parts (e.g. lubricating oil, filters, separators), which are periodically replaced. These used parts may be, or contain, substances that are regulated and must be disposed of in accordance with local, state, and federal laws and regulations.

**NOTE:** Take note of the position and locations of parts during disassembly to make reassembly easier. The assembly sequences and parts illustrated may differ for your particular unit.

Daily or before each operation	<ul style="list-style-type: none"> <li>•Check lubrication levels. Fill as needed.</li> <li>•Drain receiver tank condensate.</li> <li>•Check for unusual noise or vibration.</li> <li>•Ensure belt guards and covers are securely in place.</li> <li>•Ensure area around compressor is free from rags, tools, debris, and flammable or explosive materials.</li> </ul>
Weekly	<ul style="list-style-type: none"> <li>•Check safety/relief valves by pulling rings. Replace safety/relief valves that do not operate freely.</li> <li>•Inspect air filter element. Clean if necessary.</li> </ul>
Monthly	<ul style="list-style-type: none"> <li>•Inspect for air leaks. Squirt soapy water around joints during compressor operation and watch for bubbles. Tighten fittings if necessary.</li> <li>•Clean exterior.</li> </ul>
3 months or 500 hours	<ul style="list-style-type: none"> <li>•Change petroleum lubricant in pump while crankcase is warm.</li> </ul>
12 months or 1000 hours	<ul style="list-style-type: none"> <li>•Replace air filter element.</li> </ul>

## DRIVE BELT

Belts will stretch in normal use. Properly adjusted, a 5 pound force applied to the belt between the motor pulley and the pump will deflect the belt about 1/2".

### TO ADJUST DRIVE BELT:

1. Remove the belt guard cover.
2. Loosen the four fasteners holding the engine/motor to the compressor.
3. Shift the engine/motor in the proper direction. The belt must be properly aligned when adjustment is made.
4. To align belt, lay a straight edge against the face of the flywheel touching the rim at two places.
5. Adjust flywheel or motor pulley so that the belt runs parallel to the straight edge.
6. If necessary, use a gear puller to move the pulley on the motor shaft.
7. Check for proper belt tension (see diagram).
8. Tighten the four fasteners holding the engine/motor to the compressor.
9. Attach belt guard cover.

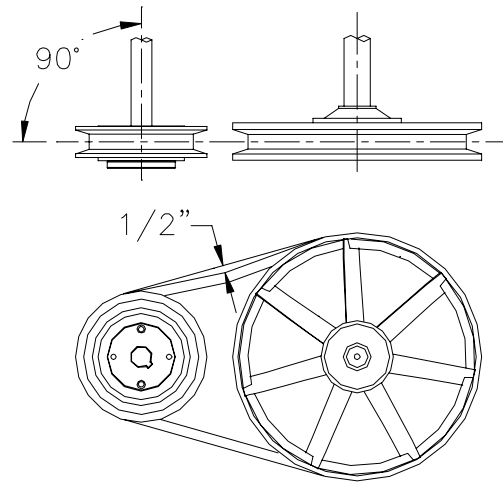

## Service Parts

Non-detergent Oil: Part #4043

# 45939 Exploded View - Rev. B

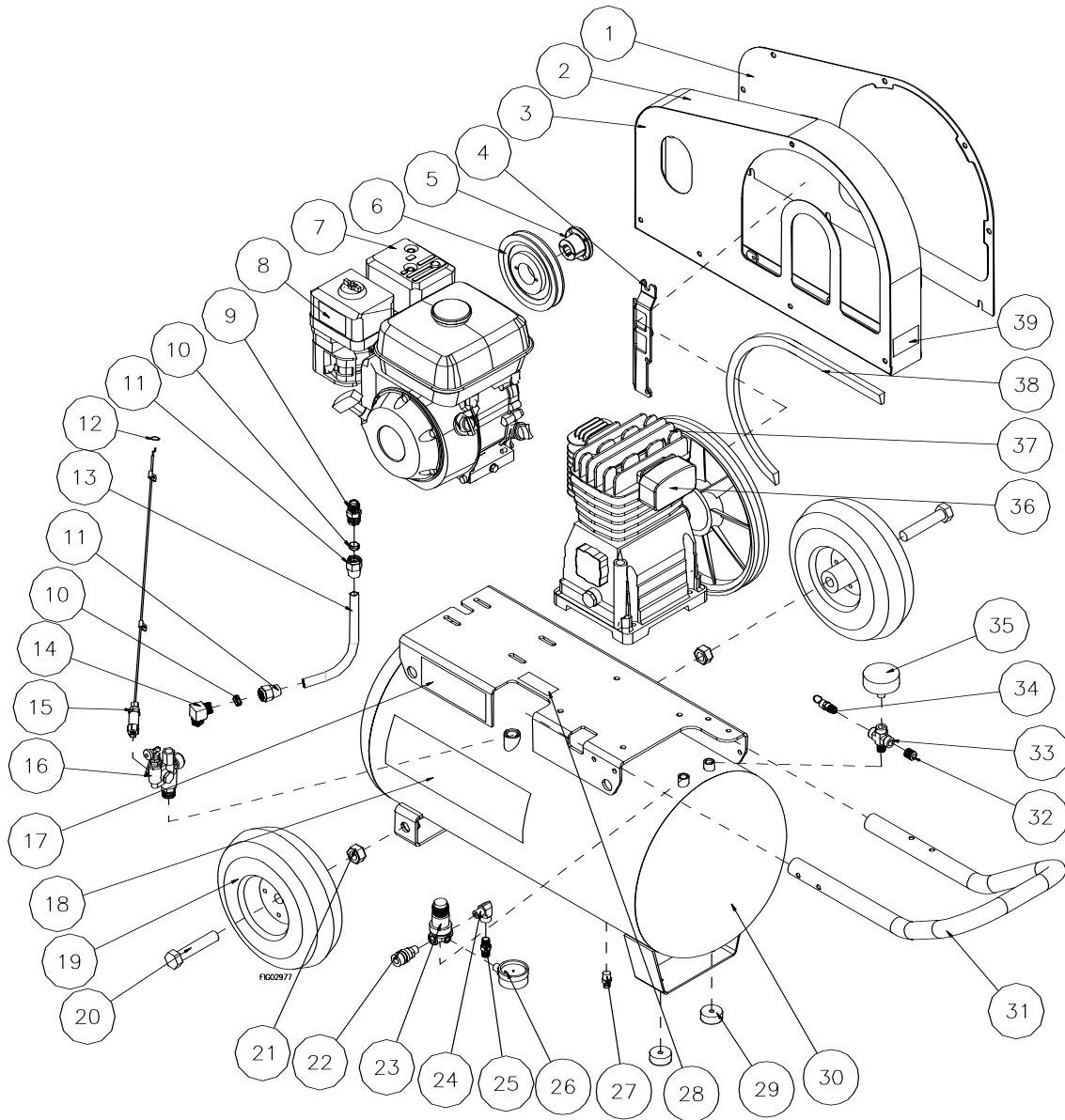

Item	Description	Part #	Qty
1	Belt Guard Cover	37636	1
2	Warning Decal	34782	1
3	Belt Guard	37633	1
4	Guard Bracket	35611	1
5	Bushing, 3/4"	33562	1
6	Sheave, AK59H	777791	1
7	Engine, Honda GX160	60590	1
8	CO Warning Decal	39259	1
9	Straight Fitting	780855	1
10	5/8" Compression Nut	35405	2
11	5/8" Compression Sleeve	34723	2
12	Honda Bushing	CD3203	1
13	Copper Tube	780798	1
14	1/2" Right Angle Fitting	34937	1
15	Idle Solenoid	35126	1
16	Unloader	780854	1
17	NorthStar Decal	784822	1
18	Operation Instruction Decal	34783	1
19	Tire	12278	2
20	3/4" x 3-3/4" Hex Bolt	82240	2

Item	Description	Part #	Qty
21	3/4" Hex Nut	82040	2
22	Quick Connect	780773	1
23	Regulator	780771	1
24	1/4" Street Elbow	780799	1
25	1/4" NPT Hex Nipple	34738	1
26	Pressure Gauge, liquid filled	780894	1
27	Drain Valve	779577	1
28	Warning Hot Decal	35064	1
29	Rubber Feet	2215	2
30	20 Gallon Tank	780835	1
31	Handle	780782	1
32	Hex Plug	777838	1
33	1/4" NPT Cross	780887	1
34	Safety Valve, 150 psi	35120	1
35	2-1/2" Bottom Mount Gauge	34699	1
36	Air Cleaner	AB2281000	1
37	Pump, B3800B	779101	1
38	Belt, A54	780833	1
39	Rotating Equip. Decal	35189	1

# 779101 Pump Assembly

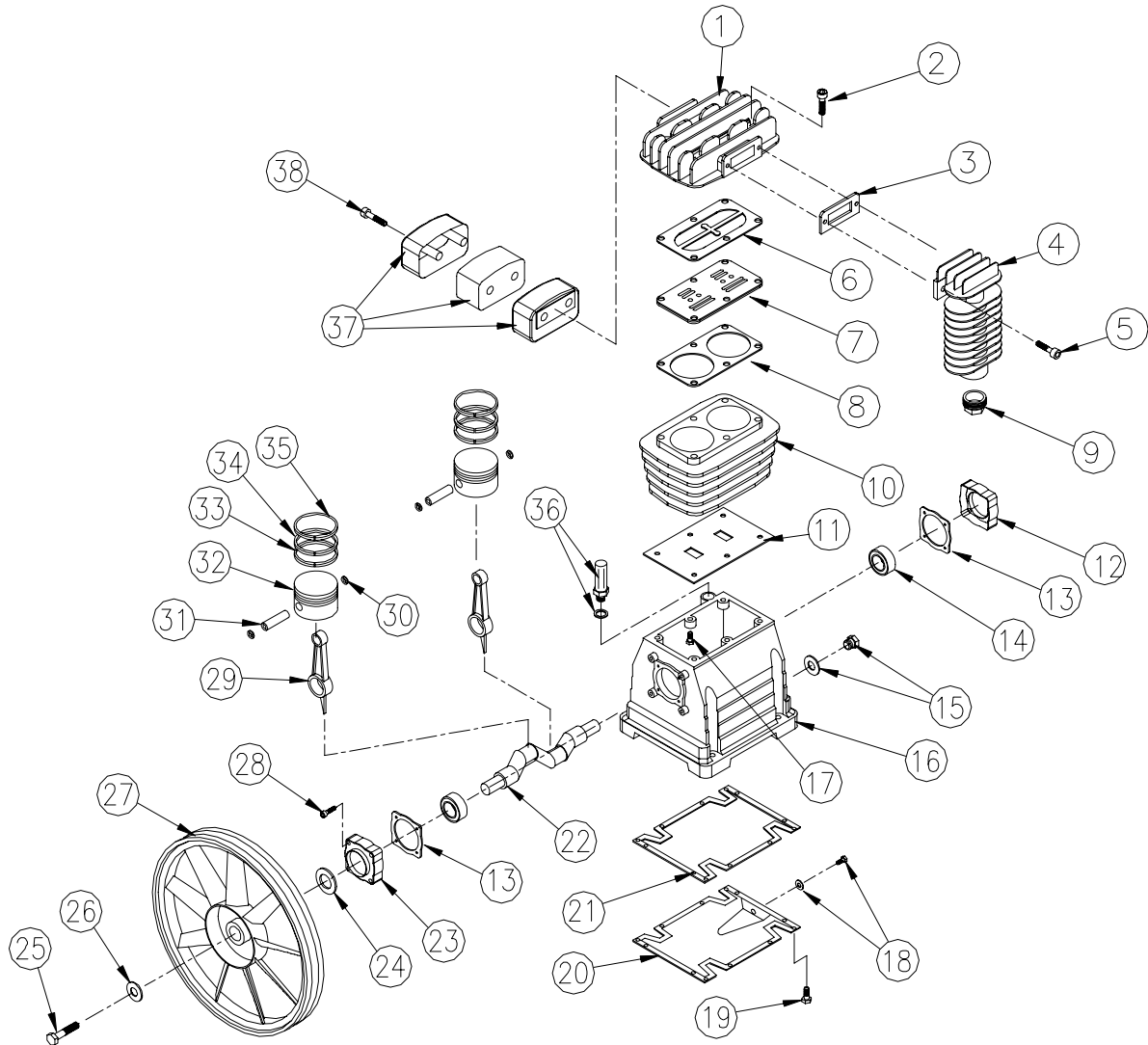

Ref	Description	Part #	Qty
1	Head	AB3860400	1
2	Head Bolt (M8 x 45mm SHCS)	AB9101594	6
3	Aftercooler Gasket	AB3670200	1
4	Aftercooler, 118mm	AB2870100	1
5	Aftercooler Bolt (M6 x 20mm SHCS)	AB9101144	2
6	Head Gasket	AB2850400	1
7	Valve Plate Assembly	AB2840050	1
8	Cylinder Gasket	AB2850300	1
9	Reducer	AB9050283	1
10	Cylinder, Cast Iron Sleeve	AB3630000	1
11	Crankcase Gasket	AB3650201	1
12	Cover N.D.E.	AB2060690	1
13	Bearing Cover Gasket	AB2050500	2
14	Bearing	AB9170030	2
15	Oil Sight Glass	AB9022001	1
16	Crankcase	AB3660100	1
17	Cylinder Bolt (M6 x 20 mm SHCS)	AB9107254	6
18	Oil Drain Plug	AB9101154	1
19	Crankcase Bottom Bolt (M5 x 15mm HHCS)	AB9119273	8
20	Oil Pan	AB3660160	1

Ref	Description	Part #	Qty
21	Oil Pan Gasket	AB3650100	1
22	Crankshaft	AB3660200	1
23	Cover D.E.	AB2060590	1
24	Oil Seal	AB9163010	1
25	Screw, Reverse Thread	AB9110014	1
26	Flywheel Washer	AB9004008	1
27	Flywheel, 350 mm	AB3600100	1
28	Bearing Housing Bolt (M6 x 15mm SHCS)	AB9101094	8
29	Connecting Rod	AB3610100	2
30	Circlip	AB9140040	4
31	Wrist Pin	AB3021200	2
32	Piston, Aluminum	AB1021100	2
33	Piston Ring, ROF	AB9020071	1
34	Piston Ring, ROS	AB9020041	1
35	Piston Ring, AC	AB9020011	1
36	Breather Cap	AB9024003	1
37	Filter Assembly	AB2281000	1
38	Filter Assembly Bolt (M6 x 25mm SHCS)	AB9114279	2
	Complete Gasket Kit	AB3650055	1

# Pneumatic Schematic Diagram

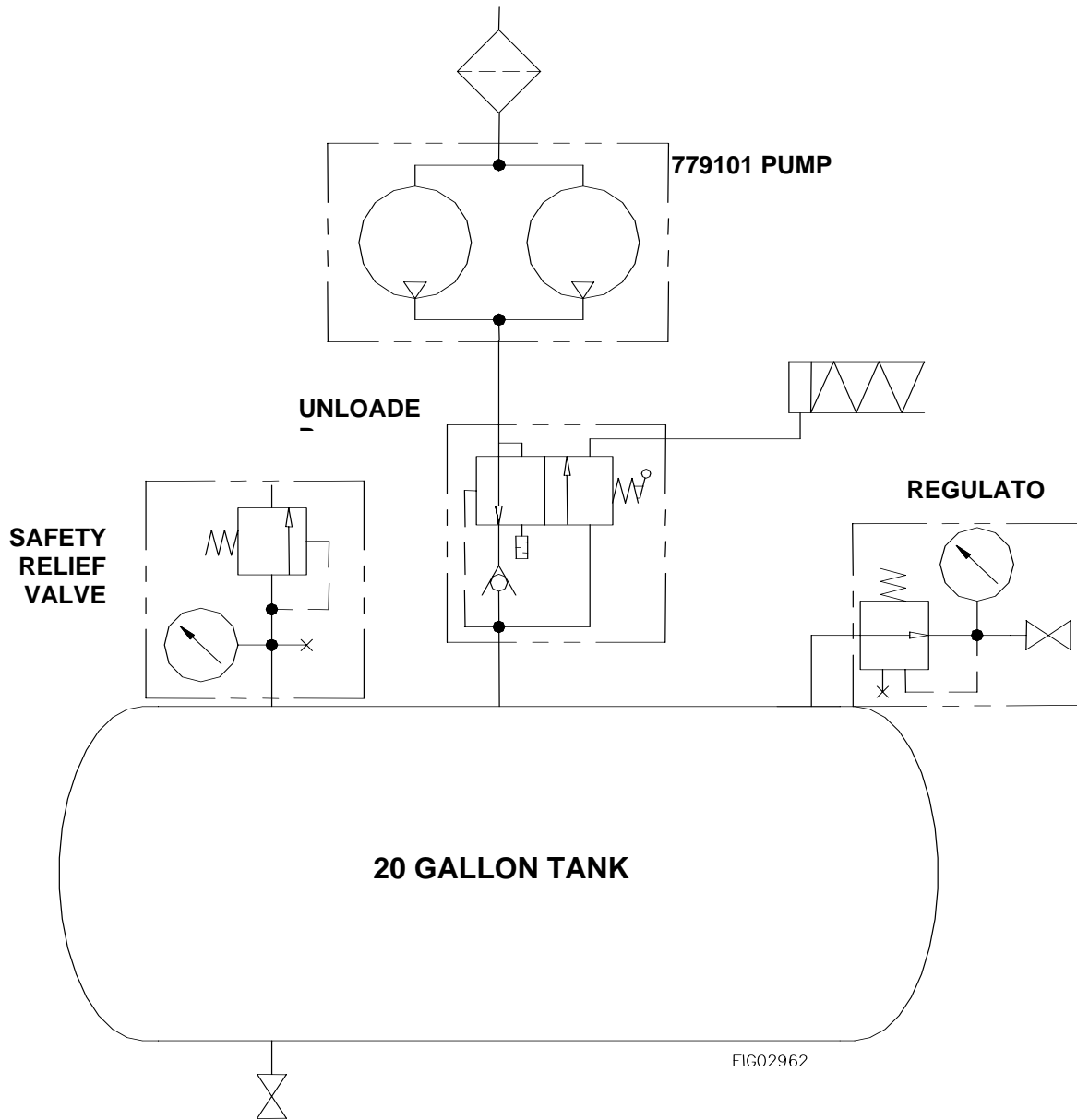

## Troubleshooting

This section provides a list of the more frequently encountered compressor malfunctions, their causes and corrective actions. Some corrective actions can be performed by the operator or maintenance personnel, and others may require assistance of a qualified electrician or Service Center.

PROBLEM	POSSIBLE CAUSE
Engine does not start.	A, B, C, D, E
Air delivery drops off.	H, I, J, L, M, N, P
Compressor does not come up to speed.	F, G, J, K
Compressor is slow to come up to speed.	F, G, J, K, L
Compressor will not unload cycle.	H, L, N, P
Compressor will not unload when stopped.	H, L, N, P
Excessive starting or stopping.	N, Q, S
Moisture in crankcase, "milky" substance in oil.	R
Oil in discharge air.	T
Safety/relief valve "pops".	L, M, N
Low interstage pressure.	W
High interstage pressure.	V

POSSIBLE CAUSE	POSSIBLE SOLUTION
A.) Low Oil Shutdown	Fill engine with the adequate amount of oil.
B.) Cold Engine	Choke engine to start.
C.) No Fuel	Add gas to engine. Make sure fuel shutoff valve is open
D.) Engine not turned ON	Place ON/OFF switch in the ON position.
E.) Spark plug wire not attached	Attach spark plug wire to spark plug.
F.) Compressor viscosity too high for ambient temperature.	Drain existing lubricant and refill with proper lubricant.
G.) Belt tension too tight or sheaves not aligned.	Check tension/ alignment.
H.) Air leaks in discharge piping.	Check tubing connections, Tighten joints or replace as required.
I.) Compressor components leaky, broken, loose.	Inspect components. Clean or replace as required.
J.) Loose flywheel or motor pulley, excessive end play in motor shaft or loose drive belts.	Check flywheel, motor pulley, and crankshaft drive belt tension/alignment. Replace or repair as required.
K.) Leaking check valve or check valve seat blown out.	Replace check valve.
L.) Clogged or dirty inlet and/or discharge line.	Clean or replace.
M.) Defective safety/relief valve.	Replace.
N.) Pressure switch unloader leaks or does not work.	Realign stem or replace.
O.) Inadequate ventilation around flywheel.	Relocate compressor for better airflow.
P.) Leaking, broken or worn inlet unloader parts at check valve.	Inspect parts and replace as required.
Q.) Excessive condensation in receiver tank.	Drain receiver tank.
R.) Detergent lubricant in crankcase.	Replace with proper lubricant.
S.) Light duty cycle.	Increase duty cycle.
T.) Lubricant level too high.	Drain excess lubricant.
U.) Worn cylinder finish.	Deglaze cylinder with 180 grit flex-hone.
V.) Low pressure inlet valve leaking.	Inspect, clean or repair as required.
W.) High pressure inlet valve leaking.	Inspect, clean or repair as required.

# Limited Warranty

Dear Valued Customer:

The NorthStar Product you just purchased is built with the finest material and craftsmanship. Use this product properly and enjoy the benefits from its high performance. By purchasing a NorthStar product, you show a desire for quality and durability.

Like all mechanical equipment this unit requires a due amount of care. Treat this unit like the high quality piece of machinery it is. Neglect and improper handling may impair its performance. Please thoroughly read the instructions and understand the operation before using your product.

## Limited Warranty

NorthStar shall warranty any piece of equipment manufactured, or parts of equipment manufactured, to be free from defects in material or workmanship for a period of 2 years from the date of purchase by user. This warranty applies to the original purchaser of the equipment and is non transferable. Verification of purchase is the responsibility of the buyer. Parts will be replaced or repaired at no charge, except when the equipment has failed due to lack of proper maintenance. Any misuse, abuse, alteration or improper installation or operations will void warranty. Determining whether a part is to be replaced or repaired is the sole decision of NorthStar.

**NOTE:** Some services performed by parties other than NorthStar may void warranty.

This warranty covers parts only. It will not provide for replacement of complete products due to defective parts.

Components not manufactured by NorthStar such as engines are guaranteed by their manufacturer and can be serviced at factory-authorized locations near you. Any costs incurred due to replacement or repair of items outside of a NorthStar approved facility is the responsibility of the buyer and not covered under warranty. NorthStar can supply you with the service center location in your area.

This warranty specifically excludes the following; failure of parts due to damage caused by accident, fire, flood, windstorm, acts of God, applications not approved by NorthStar in writing, corrosion caused by chemicals, use of replacement parts which do not conform to manufacturer's specifications, and damage caused by vandalism. Additional exclusions: loss of running time, inconvenience, loss of income, or loss of use, including any implied warranty of merchantability of fitness for a specific use.

Warranty does not cover items subject to normal wear such as tires, receptacles or any part subject to direct physical contact by the public. This warranty does not cover any personal injury or damage to surrounding property caused by failure of any part.

This warranty is in lieu of any other warranty expressed or implied and NorthStar assumes no other responsibility or liability outside that expressed within this warranty.

Please fill in the following information and have it on hand when you call in a warranty claim.

Customer Number: \_\_\_\_\_

Date of Purchase: \_\_\_\_\_

NorthStar Serial Number: \_\_\_\_\_

Item Number: \_\_\_\_\_



Manufactured by  
Northern Tool + Equipment Co.,  
2800 SouthCross Drive West  
P.O. Box 1499 Burnsville, MN 55337-0499