



# M35643L

45923; 5 HP Leeson, 19.2 PSC, 80 gal.  
 45924; 7.5 HP Leeson, 29.5 PSC, 80 gal.

## Electric Stationary Air Compressor Installation, Operation and Maintenance Manual

*To the Owner:*

Thank you for purchasing a NorthStar Air Compressor. Your machine is designed for long life, dependability, and the top performance you demand! Please take time now to read through this manual so you better understand the machine's operation, maintenance and safety precautions. Everyone who operates this machine must read and understand this manual. The time you take now will prolong your machine's life and prepare you for its safe operation. Enjoy the exceptional performance of your NorthStar Air Compressor, the industry leader! The manufacturer reserves the right to make improvements in design and/or changes in specifications at any time without incurring any obligation to install them on units previously sold.

### Quick Facts

Pump Oil	Check pump oil level before starting. Use Non-detergent pump oil (part #35605).	
Air Filter	Make sure your air filter is clean and particle free. Replacement air filter (part #35409).	
Maximum Pressure	Maximum pressure = 175 psi	
Maintenance Schedule	Tank:	Drain water daily.
	Compressor Pump:	Oil: change after first 50 hours, then every 3 months or 500 hours.

**Read and understand all manuals before operating.**

**Any Questions, Comments, Problems, or Parts Orders**  
**Call NorthStar Product Support 1-800-270-0810**

## Table of Contents

Important Safety Instructions	2	Operation	6
Receipt and Inspection	2	Maintenance / Kits & Service Parts	7
Machine Component Identification	3	Exploded View / Component List	8-11
Installation	4, 5	Troubleshooting	12
Wiring Installation	5	Limited Warranty	13

## Safety

### DEFINITIONS

#### DANGER!

WILL cause DEATH, SEVERE INJURY or substantial property damage.

#### WARNING!

CAN cause DEATH, SEVERE INJURY or substantial property damage.

#### CAUTION!

WILL or CAN cause MINOR INJURY or property damage.

### GENERAL SAFETY PRECAUTIONS

**NEVER** directly inhale compressed air.

**NEVER** over-pressurize the receiver tank or similar vessels beyond design limits.

**NEVER** use a receiver tank or similar vessels that fail to meet the design requirements of the compressor.

**NEVER** drill into, weld or otherwise alter the receiver tank or similar vessels.

**NEVER** remove, adjust, bypass, change, modify or make substitutions for safety/relief valves, pressure switches or other pressure control related devices.

**NEVER** use air tools or attachments without first determining the maximum pressure recommended for that equipment.

**NEVER** point air nozzles or sprayers toward people or animals.

**NEVER** touch the compressor pump, motor or engine or discharge tubing during or shortly after operation. These parts become hot.

**NEVER** operate where flammable or explosive liquids or vapors such as gasoline, natural gas and solvents are present.

**NEVER** remove, paint over, or deface decals. Replace any missing decals.

**NEVER** operate with guards or shields removed, damaged or broken.

**ALWAYS** follow precautions on container labels before spraying such as paint, insecticide and weed killer.

**ALWAYS** wear respirator and safety glasses when spraying.

**ALWAYS** wear eye protection when operating or servicing compressor.

### BREATHING AIR PRECAUTION

NorthStar air compressors are not designed, intended or approved for breathing air. Compressed air should not be used for breathing air applications unless treated in accordance with all applicable codes and regulations.

## Receipt and Inspection

**Ensure adequate lifting equipment is available for unloading and moving your compressor to the installation site.**

NOTE: Lifting equipment must be properly rated for the weight of the compressor.

**Caution!** Do not work on or walk under the compressor while it is suspended. Before signing the delivery receipt, inspect for damage and missing parts. If damage or missing parts are apparent, make the appropriate notation on the delivery receipt, then sign the receipt. Immediately contact the carrier for an inspection. All material must be held in the receiving location for the carrier's inspection. Delivery receipts that have been signed without a notation of damage or missing parts are considered to be delivered "clear" Subsequent claims are then considered to be concealed damage claims. Settle damage claims directly with the transportation company.

If you discover damage after receiving the air compressor (concealed damage), the carrier must be notified within 15 day of receipt and an inspection must be requested by telephone with confirmation in writing. On concealed damage claims, the burden of establishing that the compressor was damaged in transit reverts back to the claimant.

Read the compressor nameplate to verify it is the model ordered, and read the motor nameplate to verify it is compatible with your electrical conditions. Make sure electrical enclosures and components are appropriate.

**WARNING!** The installation should be made by a qualified electrician.

## Machine Component Identification

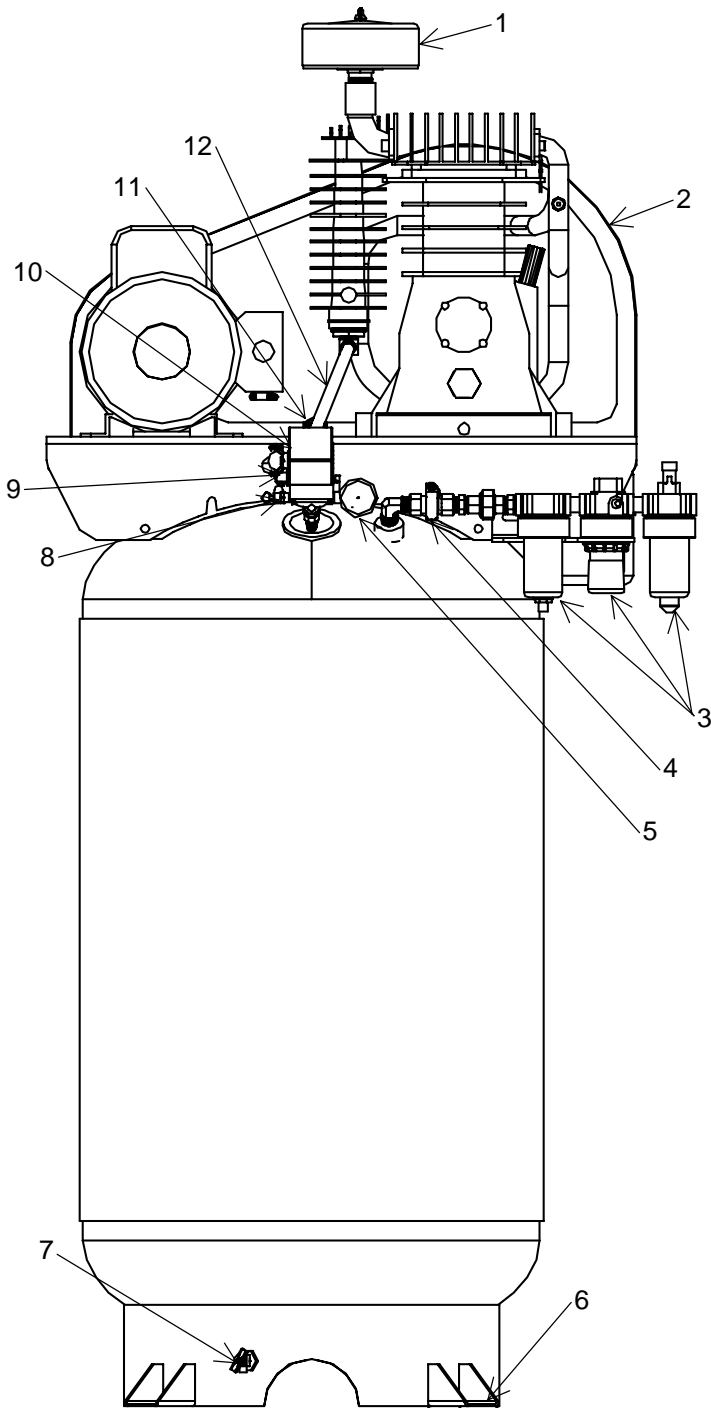

- 1.) **Air Filter** - Make sure your air filter is clean and particle free.
- 2.) **Belt Guard** - Covers the belt, motor pulley and flywheel. **NEVER** operate compressor without the belt guard or guard cover.
- 3.) **Filter/Regulator/Lubricator Kit** - NorthStar item #45925 (sold separately) The regulator controls the amount of air pressure released at the hose outlet.
- 4.) **Ball Valve** - 1/2" NPT outlet.
- 5.) **Pressure Gauge** - Easy to read gauge.
- 6.) **Mount Feet** - Use an isolation pad system to increase your compressor life.
- 7.) **Remote Drain Petcock** - This valve is located on the foot ring of the tank. Use this valve to drain moisture from the tank daily to reduce the risk of corrosion.
- 8.) **ASME Safety Valve** - This valve automatically releases air if the tank pressure exceeds the preset maximum.
- 9.) **Unloader** - Device on pressure switch which allows release of pressurized air between the tank and compressor so motor does not start under load.
- 10.) **Pressure Switch** - Auto/Off Switch - In the "auto" position, the compressor shuts off automatically when tank pressure reached the maximum preset pressure. In the "off" position, the compressor will not operate. This switch should be in the "off" position when connecting or disconnecting the power cord from the electrical outlet. **NEVER** attempt to adjust the pressure switch. Tampering with the pressure switch will void ALL warranties.
- 11.) **Check Valve** - One-way valve that allows air to enter the tank, but prevents air in the tank from flowing back into the compressor pump.
- 12.) **Discharge Tube** - This tube carries compressed air from the pump to the check valve. This tube becomes very hot during use. To avoid the risk of severe burns, never touch the discharge tube.

00854

# Installation

## SELECTING A LOCATION

Select a well lit indoor area with plenty of space for proper cooling air flow and accessibility. Locate the compressor at least 15 inches (38 cm) from walls, and make sure the power supply is clearly identified and accessible.

**Temperature.** Ideal operating temperatures are between 40° and 100°F (4° and 37° C). If temperatures consistently drop below 32° F (0° C), install the compressor inside a heated building. If this is not possible, you must protect safety/relief valves and drain valves from freezing.

### CAUTION!

**NEVER** operate in temperatures below 15° F (-9°C) or above 125° F (52°C).

**Humid Areas.** In frequently humid areas, moisture may form in the pump and produce sludge in the lubricant, causing running parts to wear out prematurely. Excessive moisture is especially likely to occur if the compressor is located in an unheated area that is subject to large temperature changes.

## PNEUMATIC SCHEMATIC

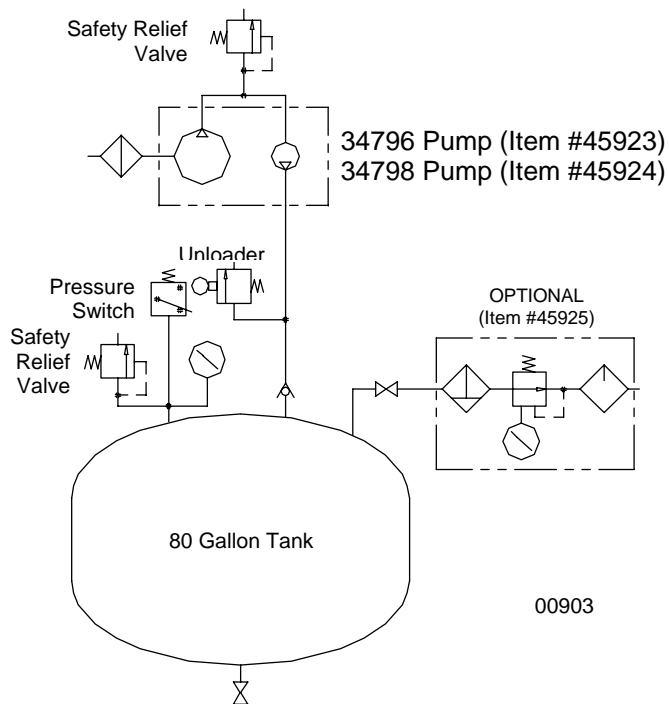

Note:  
Pressure switch automatically activates the unloader.

## INSTALLING DISCHARGE PIPING

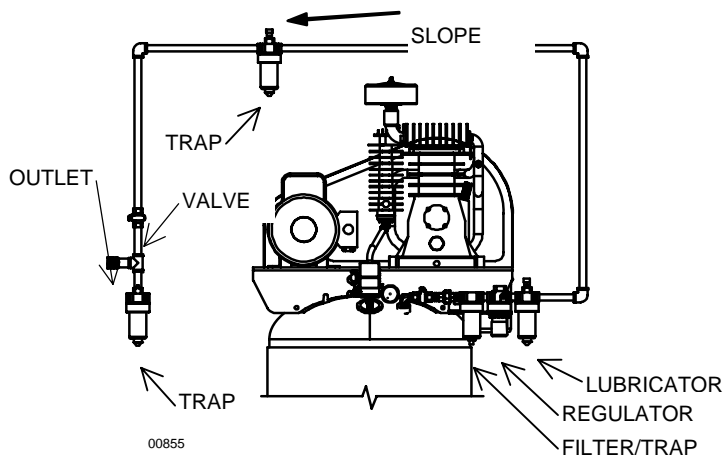

**CAUTION!** If you will be using synthetic lubricant, all downstream piping material and system components must be compatible. Refer to suitable list on page 6.

**General Requirements.** The piping, fittings, etc. must be certified for at least 4 times the working pressure. Use hard-welded, threaded steel or copper pipes and cast iron fittings that are certified safe for the compressors discharge pressure and temperature. **DO NOT USE PVC PLASTIC.** Use pipe thread sealant on all threads, and make up joints tightly to prevent air leaks.

**Main Air Distribution Line.** The main compressed air distribution line should be of sufficient size to minimize the pressure drop between the air supply and the point of use. Slope the piping downward in the direction of air flow to aid in the removal of condensation at all drain points along the line. The piping must be as short and direct as possible, and adequately braced.

**Drip Legs.** A drip leg is a pipe extending downward from the main line to collect condensation. Drip legs should be at the lowest points in the air line and at any point where the leg goes around an obstruction. A drain valve should be installed at the bottom of each drip leg.

**Drop Legs.** A drop leg is piping originating from the main air distribution line that feeds air to an outlet for tools or other air operated devices. Drop legs are taken off the top of the main line so that condensation does not easily flow into them. Drop legs should be designed so that the air outlet comes off the side of the drop leg, rather than the bottom. By doing this, the condensation which is carried from the main line collects below the outlet and prevents moisture from entering the tool or device using the air. A drain valve should be installed on the bottom of each drop leg.

**Condensation Discharge Piping.** If installing a condensation discharge line, the piping must be at least one size larger than the connection, as short and direct as possible, secured tightly and routed to a suitable drain point. Condensation must be disposed of in accordance with local, state, and federal laws and regulations.

**WARNING!** If an aftercooler, check valve, block valve, or any other restriction is added to the compressor discharge, install a properly sized ASME approved safety/relief valve between the compressor discharge and the restriction.

## Wiring Installation

**Model 45923**  
Top View - Pressure Switch

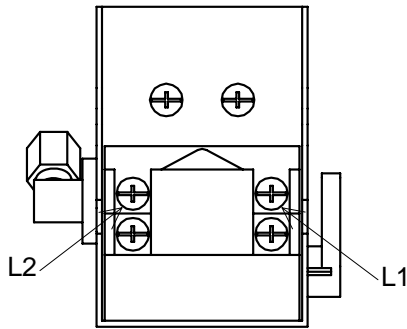

00857

**Model 45924**  
Side View - Motor Starter

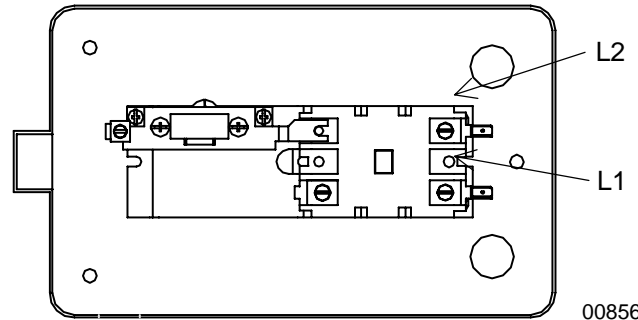

00856

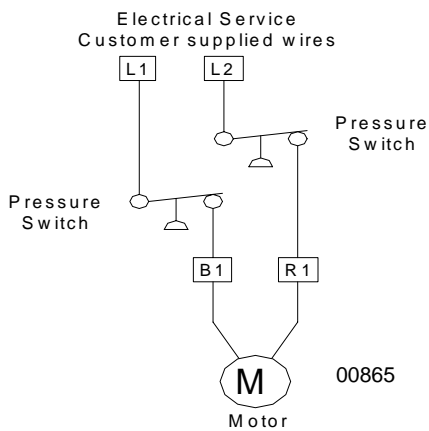

00865

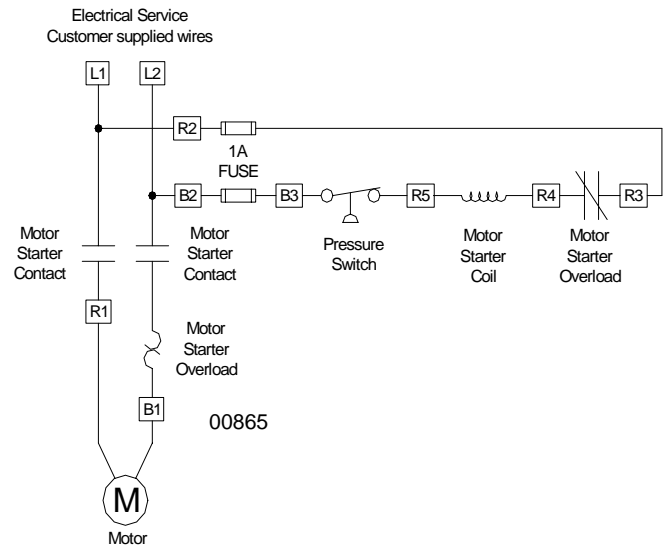

00865

**General.** The motor rating, as shown on the motor nameplate, and the power supply must have compatible voltage, phase and hertz characteristics.

**Wire Size.** The electrical wiring between the power supply and electric motor varies according to motor horsepower. Power leads must be adequately sized to protect against excessive voltage drop during start-up. Information for selecting proper wire size should be provided by a qualified electrician. If other electrical equipment is connected to the same circuit, the total electrical load must be considered in selecting the proper wire size. Do not use undersized wire.

**NOTE:** On units requiring a motor starter, connect line power to the starter. **DO NOT** connect the line power to the pressure switch.

**Magnetic Starter.** If the motor installed on your compressor has a motor reset button, it does not require a magnetic starter. If the motor does not have this button, connect the power leads to the starter located under the compressor top plate.

**Circuit Breaker.** Refer to the National Electric Code to determine the proper circuit breaker rating required. When selecting a circuit breaker, remember the momentary starting current of an electric motor is greater than its full load current. Time delay or "slow-blow" circuit breakers are recommended.

**WARNING!** The installation should be made by a qualified electrician. If the products must be reconnected for use on different types of circuits, the re-connection should be made by qualified personnel.

# Operation

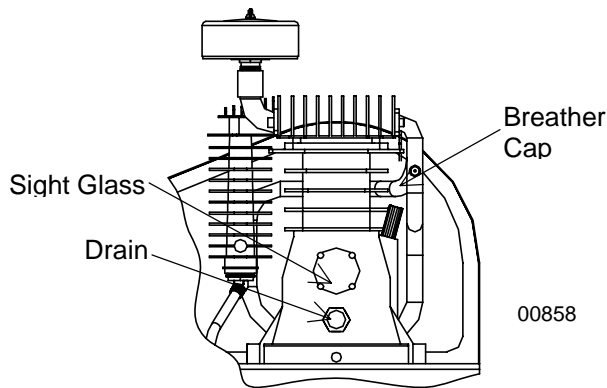

## INITIAL START-UP

1. Pump is shipped with oil. Remove the oil cap and check pump oil level. Add SAE 30 Non-detergent pump oil (NorthStar part #35605), if necessary. Hand tighten breather cap.

2. Turn outlet valve to open airflow.

3. Move pressure switch lever to the OFF position and plug in power cord (if applicable). Move pressure switch to the AUTO position to run the unit.

**CAUTION!** Unusual noise or vibration indicates a problem. Do not continue to operate until you identify and correct the source of the problem.

**NOTE:** Electric models are equipped with a pressure switch that automatically turns the motor OFF when the tank pressure reaches a preset level. After air is used from the tank and drops to a preset low level, the pressure switch automatically turns the motor back on.

**CAUTION!** Do not attach air tools to open end of the hose until start-up is completed and the unit checks out OK.

4. Run the unit for 30 minutes, with ball valve open, to break in pump parts.

5. Move the pressure switch lever to OFF and turn the outlet valve to shut off air flow. The compressor is now ready for use.

6. After 50 hours of operation change the compressor oil.

## WARNING!

Never disconnect threaded joints with pressure in the tank.

**NOTE:** Reduce tank pressure below 10 psi, then drain moisture from tank daily to avoid tank corrosion. Drain moisture from tank(s) by opening the drain petcock located on the foot ring.

## COMPRESSOR LUBRICATION

**CAUTION!** Do not operate without lubricant or with inadequate lubricant. Use of compressor without lubricant or inadequate lubricant voids all warranties.

### Synthetic Lubricants

Synthetic lubricants are recommended after 50 hour break-in. Compressor life is greatly increased with the use of synthetic lubricants. **CAUTION!** If you will be using synthetic lubricant, all downstream piping material and system components must be compatible.

**Suitable** Viton®, Teflon®, Epoxy (Glass Filled), Oil Resistant Alkyd, Fluorosilicone, Fluorocarbon, Polysulfide, 2-Component Urethane, Nylon, Delrin®, Celcon®, High Nitrile Rubber (Buna N. NBR more than 36 Acrylonite), Polyurethane, Polyethylene, Epichlorohydrin, Polyacrylate, Melamine, Polypropylene, Baked Phenolics, Epoxy, Modified Alkyds

(® indicates trademark of DuPont Corporation)

### Not Recommended

Neoprene, Natural Rubber, SBR Rubber, Acrylic Paint, Lacquer, Varnish, Polystyrene, PVC, ABS, Polycarbonate, Cellulose Acetate, Latex, EPR, Acrylics, Phenoxy, Polysulfones, Styrene Acrylonitile (San), Butyl

**Alternate Lubricants.** You may use petroleum-based lubricant that is premium quality, does not contain detergents, contains only anti-rust, anti-oxidation, and anti-foam agents as additives, has a flashpoint of 440°F (227°C) or higher, and has a auto-ignition point of 650°F (343°C) or higher.

See the petroleum lubricant viscosity table below. The table is intended as a general guide only. Heavy duty operating conditions require heavier viscosities.

Temperature around Compressor	Viscosity Grade	
	ISO	SAE
Below 40°F (4°C)	60	20
40°F to 80°F (4°C to 27°C)	100	30
80°F to 100°F (27°C to 37°C)	150	40

## Pump Crankcase Capacities.

Model	Crankcase capacity
45923	42 oz
45924	82 oz

## MOISTURE IN COMPRESSED AIR

Moisture in compressed air will form into droplets as it comes from an air compressor pump. When humidity is high or when a compressor is in continuous use for an extended period of time, this moisture will collect in the tank. When using a paint spray or sandblast gun, this water will be carried from the tank through the hose, and out of the gun as droplets mixed with the spray material. If this is not acceptable for your application, an external air dryer must be added to the system.

## Maintenance

**WARNING!** Disconnect, lock and tag main power supply and release air pressure from system before performing maintenance.

**NOTE:** All compressed air systems contain maintenance parts (e.g. lubricating oil, filters, separators) which are periodically replaced. These used parts may be, or contain, substances that are regulated and must be disposed of in accordance with local, state, and federal laws and regulations.

**NOTE:** Take note of the position and locations of parts during disassembly to make reassembly easier. The assembly sequences and parts illustrated may differ for your particular unit.

Daily or Before each operation	<ul style="list-style-type: none"> <li>•Check lubrication level. Fill as needed.</li> <li>•Drain receiver tank condensation.</li> <li>•Check for unusual noise or vibration.</li> <li>•Ensure belt guards and covers are securely in place.</li> <li>•Ensure area around compressor is free from rags, tools, debris, and flammable or explosive materials.</li> </ul>
Weekly	<ul style="list-style-type: none"> <li>•Check safety/relief valves by pulling rings. Replace safety/relief valves that do not operate freely.</li> <li>•Inspect air filter element. Clean if necessary.</li> </ul>
Monthly	<ul style="list-style-type: none"> <li>•Inspect for air leaks. Squirt soapy water around joints during compressor operation and watch for bubbles. Tighten fittings if necessary.</li> <li>•Clean exterior.</li> </ul>
3 months or 500 hours	<ul style="list-style-type: none"> <li>•Change pump oil while crankcase is warm.</li> </ul>
12 months or 1000 hours	<ul style="list-style-type: none"> <li>•Replace air filter element.</li> </ul>

### DRIVE BELT

Belts will stretch in normal use. Properly adjusted, a 5 pound force applied to the belt between the motor pulley and the pump will deflect the belt about 1/2".

#### TO ADJUST DRIVE BELT:

1. Remove belt guard cover.
2. Loosen the four fasteners holding the motor to the top plate.
3. Shift the motor in the proper direction. The belt must be properly aligned when adjustment is made.
4. To align belt, lay a straight edge against the face of the flywheel touching the rim at two places.
5. Adjust flywheel or motor pulley so that the belt runs parallel to the straight edge.
6. If necessary, use a gear puller to move the pulley on the motor shaft. Tighten set screw after pulley is positioned.
7. Check for proper belt tension (see diagram).
8. Tighten the four fasteners holding the motor to the top plate.
9. Attach belt guard cover.

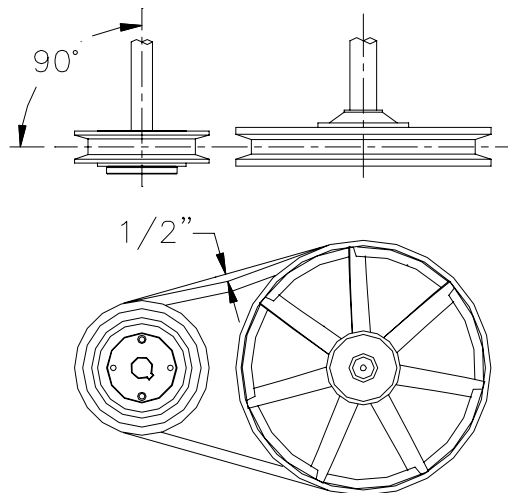

00882

## Kits and Service Parts

Filter/Regulator/Lubricator Kit  
Item #45925

Air Filter Element  
Part #35409

Pump Gasket Kit (45924)  
Part #AB6050057

Pump Oil  
Part #35605

Pump Gasket Kit (45923)  
Part #AB4950055

**Exploded View – Rev L**  
**Model 19.2 PSC (Item #45923), Model 29.5 PSC (Item #45924)**

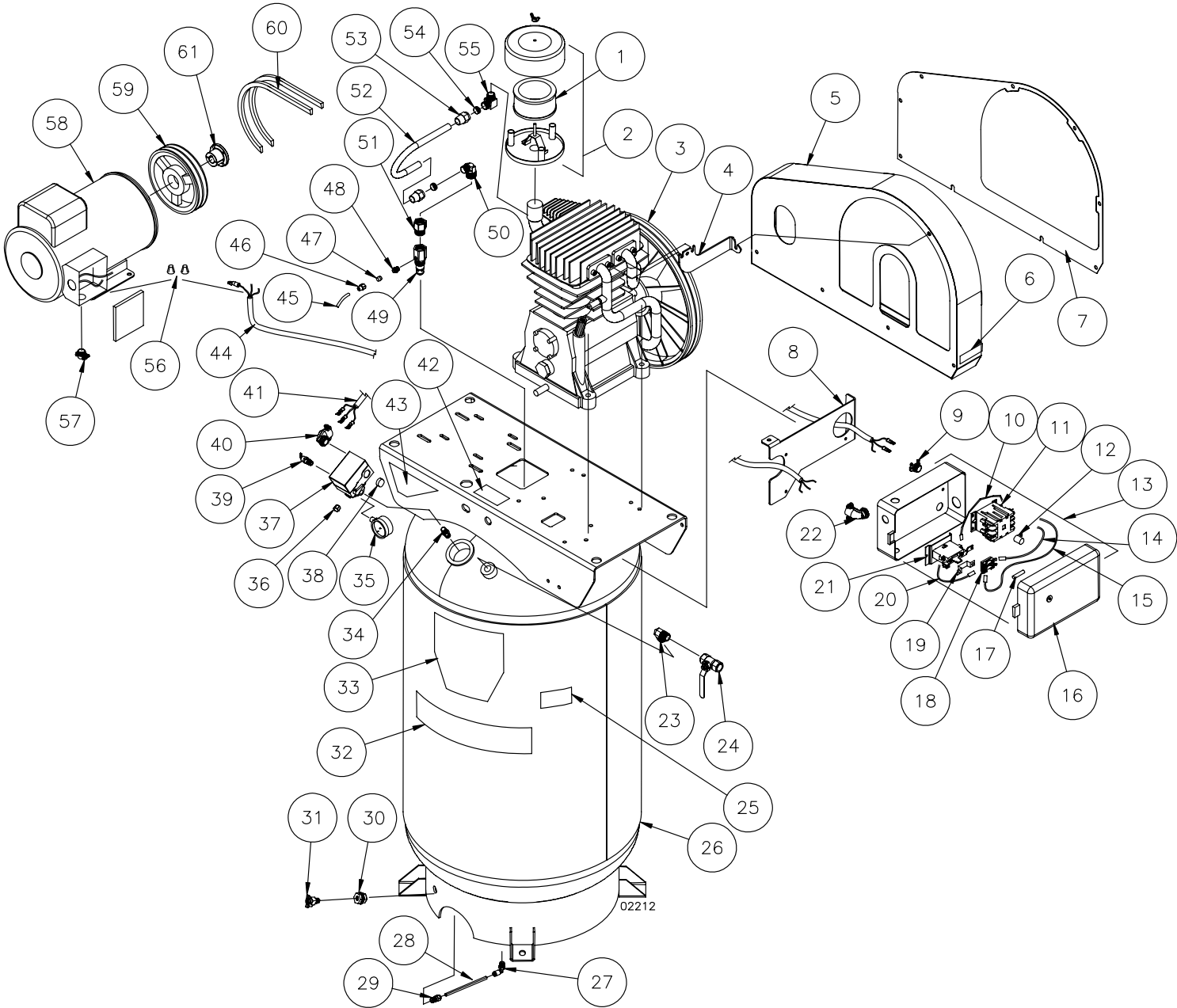

## #45923 and #45924 Component List – Rev. L

Item	Description	Model	Part #	Qty	Item	Description	Model	Part #	Qty
1	Air Filter	ALL	35409	1	34	1/4" NPT Hex Nipple	ALL	34738	1
2	Air Filter Assembly	45923	35603	1	35	2" Air Gauge	ALL	34710	1
		45924	35404	1	36	1/4" NPT Plug	ALL	2249	1
3	Air Compressor	45923	779102	1	37	Pressure Switch/Unloader	ALL	35123	1
		45924	779103	1	38	Dome Cap	45924	35417	1
4	Belt Guard Mount Bracket	45923	37135	1	39	Safety Relief, 200 psi	ALL	35121	1
		45924	35657	1	40	Strain Relief (12-3 Rt. Angle)	ALL	34759	1
5	Belt Guard	ALL	37639	1	41	Power Cord (12-3, S00W)	45923	35388	1
6	Rotating Equip. Decal	ALL	35189	1			45924	35384	1
7	Belt Guard Cover	ALL	37642	1	42	Warning Decal	ALL	35064	1
8	Starter Bracket	45924	37136	1	43	Instruction Decal	ALL	35066	1
9	Strain Relief (12-3 Straight)	45924	777215	1	44	Power Cord (8-3, S00W)	45924	35385	1
10	Wire Assembly (R4)	45924	36048	1					
11	Motor Relay	45924	35421	1	45	1/4" Copper Tube	ALL	35645	1
12	Grounding Post	45924	32754	1	46	1/4" Compression Nut	ALL	34740	2
13	Motor Starter	45924	34755	1	47	1/4" Compression Sleeve	ALL	34737	2
14	Wire Assembly (R2)	45924	35382	1	48	1/8" MPT x 1/4" Comp. Fitting	ALL	34741	1
15	Wire Assembly (B3)	45924	35383	1					
16	Controller Box	45924	35422	1	49	Check Valve	ALL	777221	1
17	Fuse	45924	35386	2	50	3/4" NPT x 5/8" Comp.	ALL	777255	1
18	Fuse Holder	45924	35387	1	51	Adapter	ALL	36107	1
19	Bi-metal Heater	45924	35423	1	52	5/8" Copper Tube	45923	37157	1
20	Wire Assembly (R3)	45924	36047	1			45924	36108	1
21	Overload Relay	45924	35424	1	53	5/8" Compression Nut	ALL	34724	2
22	Strain Relief (8-3 Rt Angle)	45924	34758	1	54	5/8" Compression Sleeve	ALL	34723	2
23	1/2" NPT Elbow	ALL	34739	1	55	90 deg 5/8" Comp x 1/2" MPT Fitting	ALL	34937	1
24	1/2" Ball Valve	ALL	34733	1					
25	Name Plate	45923	35183	1	56	Wire Nut	45923	305279	2
		45924	35185	1			45924	35408	2
26	80 Gal Tank, Red	ALL	37172	1	57	Strain Relief	45923	777215	1
27	1/4" Rt Angle Connection	ALL	35406	1			45924	35416	1
28	1/4" Diameter HDPE Tube	ALL	34746	10.5"	58	5 HP Leeson Motor 7.5 HP Leeson Motor	45923	778670	1
29	1/4" Straight Connection	ALL	34745	1			45924	781802	1
30	1/4" NPT Bulkhead Fitting	ALL	34744	1	59	Sheave, AK54H Sheave, 2AK59H	45923	35625	1
31	1/4" NPT Water Drain	ALL	35413	1			45924	35663	1
32	Warning Decal	ALL	35190	1	60	Belt, A60 Belt, A66	45923	37174	1
33	NorthStar Decal	ALL	777725	1			45924	35664	2
61	Bushing, H 3/4 Bushing, H 1-1/8	ALL	777725	1	45923	33562	45924	34750	1

# 779102 Pump Assembly

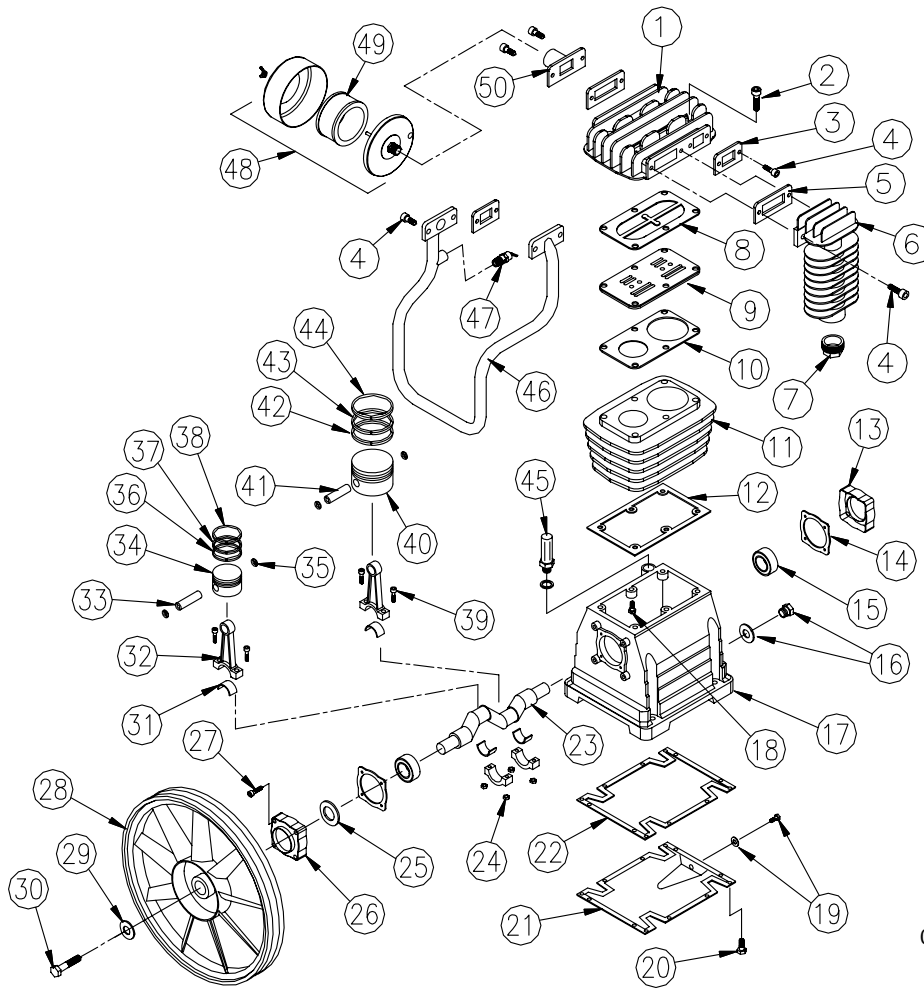

00863

Item	Description	Part #	Qty
1	Pump Head	AB4961400	1
2	Head Bolt (M8 x 55mm SHCS)	AB9101744	6
3	Intercooler Gasket	AB4650600	2
4	Intercooler/Aftercooler Bolt (M8 x 20mm SHCS)	AB9101254	8
5	Gasket	AB3970200	2
6	Aftercooler	AB2070100	1
7	Reducer	AB9050282	1
8	Head Gasket	AB4650400	1
9	Valve Plate Assembly	AB4940050	1
10	Cylinder Gasket	AB4950300	1
11	Cylinder, Cast Iron Sleeve	AB4930000	1
12	Frame Gasket	AB4950200	1
13	Cover N.D.E.	AB2060690	1
14	Bearing Cover Gasket	AB2050500	2
15	Bearing	AB9170010	2
16	Oil Sight Glass	AB9022001	1
17	Crankcase	AB4960101	1
18	Cylinder Bolt	AB9107254	6
19	Crankcase Plug	AB9101164	1
20	Crankcase Bolt (M5 x 15 HHCS)	AB9114271	12
21	Crankcase Pan	AB4961301	1
22	Crankcase Gasket	AB4950101	1
23	Crankshaft	AB4961200	1
24	Nut	AB9128234	4
25	Oil Seal	AB9163010	1
26	Cover D.E.	AB2060590	1

Item	Description	Part #	Qty
27	Cover Bolt (M6 x 15 SHCS)	AB9101094	8
28	Flywheel, 350 mm	AB3600100	1
29	Flywheel washer	AB9004008	1
30	Screw, Reverse Thread	AB9110014	1
31	Half Bearing	AB9013011	4
32	Connecting Rod	AB4011101	2
33	Wrist Pin	AB4621200	1
34	H.P. Piston, Aluminum	AB4621100	1
35	Circlip	AB9140050	4
36	Piston Ring ROF	AB9020086	2
37	Piston Ring ROS	AB9020053	1
38	Piston Ring AC	AB9020023	1
39	Rod Bolt	AB9106244	4
40	L.P. Piston, Aluminum	AB4922100	1
41	Wrist Pin	AB4922200	1
42	Piston Ring ROF	AB9020057	1
43	Piston Ring ROS	AB9020056	1
44	Piston Ring AC	AB9020055	1
45	Oil fill plug	AB9024010	1
46	Intercooler	AB4662000	1
47	Safety Valve	AB9049064	1
48	Air Filter Assembly	35603	1
49	Air Filter	35409	1
50	Intake Manifold	35604	1
	Complete Gasket Kit	AB4950055	1

# 779103 Pump Assembly

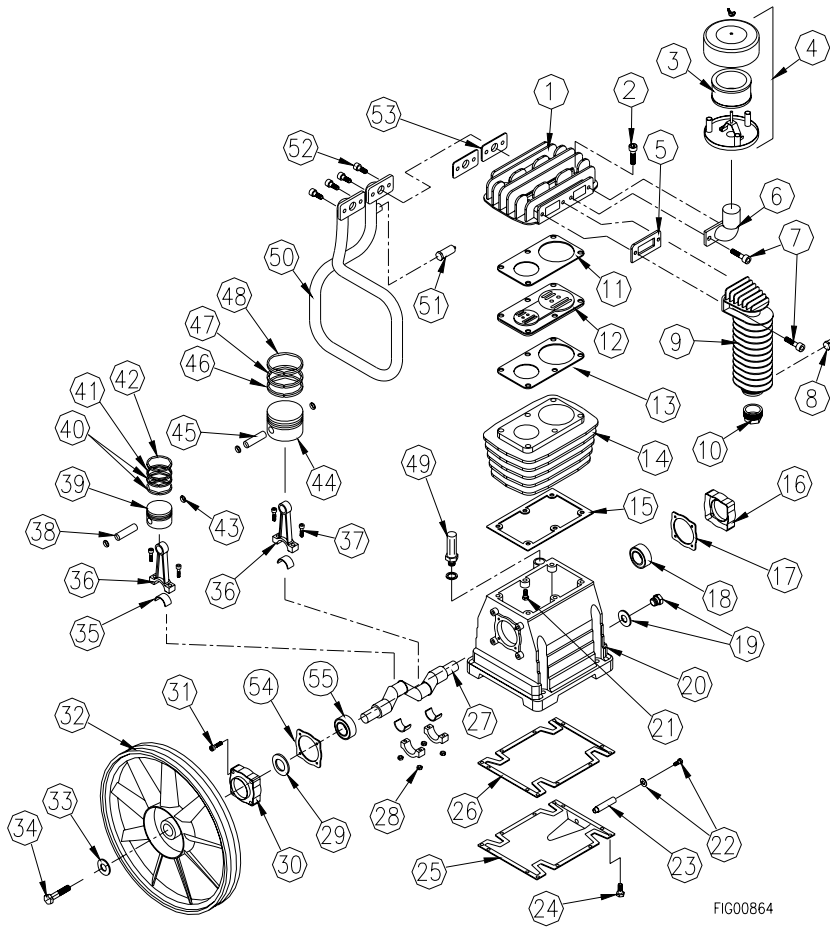

FIG00864

Item	Description	Part #	Qty
1	Pump Head	AB6061401	1
2	Head Bolt (M10 x 55mm SHCS)	AB9101754	6
3	Air Filter	35409	1
4	Air Filter Assy.	35404	1
5	Intake/Aftercooler Gasket	AB5070200	1
6	Intake Elbow	AB9083227	1
7	Intake/Aftercooler Bolt (M10 x 20 SHCS)	AB9101264	4
8	Safety Valve	AB9049011	1
9	Aftercooler	AB5070100	1
10	Reducer	AB9050284	1
11	Head Gasket	AB6050400	1
12	Valve Plate Assy.	AB6040051	1
13	Cylinder Gasket	AB6050300	1
14	Cylinder, Cast Iron	AB6030000	1
15	Upper Crankcase Gasket	AB6050200	1
16	Cover N.D.E.	AB5061690	1
17	Bearing Cover Gasket	AB5050500	1
18	Bearing	AB9170020	1
19	Oil Sight Glass	AB9022003	1
20	Crankcase	AB6061100	1
21	Cylinder Bolt (M10 x 40mm SHCS)	AB9101324	6
22	Crankcase Plug	AB9101164	1
23	Oil Drain Stub	AB9053201	1
24	Crankcase Bolt (M6 x 20mm HHCS)	AB9114262	12
25	Crankcase Pan	AB6061301	1
26	Lower Crankcase Gasket	AB6050101	1
27	Crankshaft	AB6061200	1
28	Rod Nut	AB9128234	4

Item	Description	Part #	Qty
29	Oil Seal	AB9163030	1
30	Cover D.E.	AB6061590	1
31	Cover Bolt (M6 x 15mm SHCS)	AB9101154	8
32	Flywheel, 430 mm	AB5000100	1
33	Flywheel washer	AB9004009	1
34	Screw, Reverse Thread	AB9110024	1
35	Half Bearing	AB9013014	4
36	Connecting Rod	AB6011101	2
37	Rod Bolt	AB9106244	4
38	Pin, High Pressure	AB6021200	1
39	H.P. Piston, Aluminum	AB6021100	1
40	Piston Ring ROF	AB9020073	2
41	Piston Ring ROS	AB9020041	1
42	Piston Ring AC	AB9020011	1
43	Circlip	AB9140060	4
44	L.P. Piston, Aluminum	AB6022100	1
45	Pin, Low Pressure	AB6022200	1
46	Piston Ring ROF	AB9020076	1
47	Piston Ring ROS	AB9020046	1
48	Piston Ring AC	AB9020016	1
49	Oil fill plug	AB9024006	1
50	Intercooler	AB5262010	1
51	Safety Valve	AB9049064	1
52	Intercooler Bolt (M8 x 20 mm SHCS)	AB9101254	4
53	Intercooler Gasket	AB5050600	2
54	Front Bearing Cover Gasket	AB6050500	1
55	Front Main Bearing	AB9170090	1
	Complete Gasket Kit	AB6050057	1

## Troubleshooting

This section provides a list of the more frequently encountered compressor malfunctions, their causes and corrective actions. Some corrective actions can be performed by the operator or maintenance personnel, and others may require assistance of a qualified electrician or Service Center.

PROBLEM	POSSIBLE CAUSE
Motor does not turn.	A, B, C, D, E
Motor overload trips or draws excessive current.	D, G, M
Excessive noise, vibration, knocking or rattling.	H, I, K, L, N, O, P, R, W
Lights flicker or dim when running.	C, D, E, J, M
Air delivery drops off.	I, P, L, M, N, O, P, R, W, X, Y
Compressor does not come up to speed.	C, D, F, H, L, M, P
Compressor is slow to come up to speed.	C, D, F, H, L, M, N
Compressor will not unload cycle.	I, N, P, R
Compressor will not unload when stopped.	I, N, P, R
Excessive starting or stopping.	D, E, G, P, S, U
Moisture in crankcase, "milky" substance in oil.	T
Oil in discharge air.	V
Safety/relief valve "pops".	N, O, P
Low interstage pressure.	Y
High interstage pressure.	X

POSSIBLE CAUSE	POSSIBLE SOLUTION
A.) Circuit breaker on motor tripped.	Push button located on back of motor.
B.) Supply line circuit breaker tripped.	Reset circuit breaker.
C.) Wiring or electric service panel too small.	Install properly sized wire or service box. Contact electrician.
D.) Compressor wired incorrectly.	Check wiring, contact electrician.
E.) Poor contact on motor terminals or starter connections	Ensure good contact on motor terminals or starter connections.
F.) Compressor viscosity too high for ambient temperature.	Drain existing lubricant and refill with proper lubricant.
G.) Poor ground.	Check all ground connections.
H.) Belt tension too tight or sheaves not aligned.	Check tension/alignment.
I.) Air leaks in discharge piping.	Check tubing connections, Tighten joints or replace as required.
J.) Poor power regulation.	Contact power company.
K.) Compressor components leaky, broken, loose.	Inspect components. Clean or replace as required.
L.) Loose flywheel or motor pulley, excessive end play in motor shaft or loose drive belts.	Check flywheel, motor pulley, crankshaft drive belt tension/alignment. Replace or repair as required.
M.) Leaking check valve or check valve seat blown out.	Replace check valve.
N.) Clogged or dirty inlet and/or discharge line.	Clean or replace.
O.) Defective safety/relief valve.	Replace.
P.) Pressure switch unloader leaks or does not work.	Replace.
Q.) Inadequate ventilation around flywheel.	Relocate compressor for better air flow.
R.) Leaking, broken or worn inlet unloader parts at check valve.	Inspect parts and replace as required.
S.) Excessive condensation in receiver tank.	Drain receiver tank.
T.) Detergent lubricant/water in crankcase.	Replace with proper lubricant.
U.) Light duty cycle.	Increase duty cycle.
V.) Lubricant level too high.	Drain excess lubricant.
W.) Worn cylinder finish.	Deglaze cylinder with 180 grit flex-hone.
X.) Low pressure inlet valve leaking.	Inspect, clean or repair as required.
Y.) High pressure inlet valve leaking.	Inspect, clean or repair as required.

# Limited Warranty

Dear Valued Customer:

The NorthStar Product you just purchased is built with the finest material and craftsmanship. Use this product properly and enjoy the benefits from its high performance. By purchasing a NorthStar product, you show a desire for quality and durability.

Like all mechanical equipment this unit requires a due amount of care. Treat this unit like the high quality piece of machinery it is. Neglect and improper handling may impair its performance. Please thoroughly read the instructions and understand the operation before using your product.

## Limited Warranty

NorthStar shall warranty any piece of equipment manufactured, or parts of equipment manufactured, to be free from defects in material or workmanship for a period of 2 years from the date of purchase by user. This warranty applies to the original purchaser of the equipment and is non transferable. Verification of purchase is the responsibility of the buyer. Parts will be replaced or repaired at no charge, except when the equipment has failed due to lack of proper maintenance. Any misuse, abuse, alteration or improper installation or operations will void warranty. Determining whether a part is to be replaced or repaired is the sole decision of NorthStar.

**NOTE:** Some services performed by parties other than NorthStar may void warranty.

**This warranty covers parts only. It will not provide for replacement of complete products due to defective parts. Components not manufactured by NorthStar such as engines are guaranteed by their manufacturer and can be serviced at factory-authorized locations near you. Any costs incurred due to replacement or repair of items outside of a NorthStar approved facility is the responsibility of the buyer and not covered under warranty. NorthStar can supply you with the service center location in your area.**

This warranty specifically excludes the following; failure of parts due to damage caused by accident, fire, flood, windstorm, acts of God, applications not approved by NorthStar in writing, corrosion caused by chemicals, use of replacement parts which do not conform to manufacturer's specifications, and damage caused by vandalism. Additional exclusions: loss of running time, inconvenience, loss of income, or loss of use, including any implied warranty of merchantability of fitness for a specific use.

Warranty does not cover items subject to normal wear such as tires, receptacles or any part subject to direct physical contact by the public. This warranty does not cover any personal injury or damage to surrounding property caused by failure of any part.

This warranty is in lieu of any other warranty expressed or implied and NorthStar assumes no other responsibility or liability outside that expressed within this warranty.

Please fill in the following information and have it on hand when you call in a warranty claim.

Customer Number: \_\_\_\_\_

Date of Purchase: \_\_\_\_\_

NorthStar Serial Number: \_\_\_\_\_

Item Number: \_\_\_\_\_



Manufactured by  
Northern Tool + Equipment Co.,  
2800 SouthCross Drive West  
P.O. Box 1499 Burnsville, MN 55337-0499