



M2682270E

ITEM NUMBER: 2681040, 2682270,
2683060, 2684060, 2685560

SERIAL NUMBER: _____

Owner's Manual

Instructions for Assembly, Testing, Operation, Servicing, and Storage

12V Diaphragm Pump: For use with agricultural pesticides and other liquids**

WARNING

READ and UNDERSTAND the Owner's Manual completely before using this pump. Assemble, test, and use only in accordance with the Owner's Manual instructions.

READ and FOLLOW chemical safety instructions. Pesticides are hazardous chemicals.

KNOW emergency procedures BEFORE handling chemicals. Pump leaks, bodily chemical contact, poisoning, and spills require immediate response.

AVOID inhaling, ingesting, or coming into contact with any chemicals.

WEAR personal protective gear when operating, cleaning, and servicing the pump.

KEEP pump and spray materials away from children and pets. Pesticides are especially toxic to them.

DO NOT TURN ON POWER to pump until ready to spray in order to avoid unintentional spray release.

Improper use of the pump or handling of chemicals could result in serious injury or illness to the operator or nearby persons/animals, or could cause damage to the environment.

** This pump is recommended for use in spraying non-flammable liquids such as pesticides, water for plants/trees or dust control, ice control chemicals, or water-based non-flammable sealants or stains for outdoor wood surfaces. However, WE RECOMMEND THAT THE PUMP NOT BE USED FOR OTHER PURPOSES ONCE IT HAS BEEN USED FOR SPRAYING PESTICIDES. Any chemical will leave some residual in the pump, even after the pump has been properly cleaned. These residual chemicals can have unexpected effects on future uses. For example, spraying water or other liquids that are contaminated with residual pesticide may result in unforeseen hazards to plant or animal life.

Any Questions, Comments, Problems, or Parts Orders
Call NorthStar Product Support 1-800-270-0810

Hazard Signal Word Definitions





	<p>This is the safety alert symbol. It is used to alert you to potential personal injury hazards. Obey all safety messages that follow this symbol to avoid possible injury or death.</p>
	<p>DANGER (red) indicates an imminently hazardous situation which, if not avoided, will result in death or serious injury.</p>
	<p>WARNING (orange) indicates a potentially hazardous situation which, if not avoided, could result in death or serious injury.</p>
	<p>CAUTION (yellow) indicates a potentially hazardous situation which, if not avoided, may result in minor or moderate injury.</p>
	<p>CAUTION (yellow) used without the safety alert symbol indicates a potentially hazardous situation which, if not avoided, may result in property damage.</p>

fig01453

Table of Contents

Intended Use	4
Summary of Important Safety Information	5
During Assembly	
During Operation	
• General Chemical Safety	
• Chemical Applicator Safety	
• Chemical Accident Procedures	
Installation	
Step One: Mounting	7
Step Two: Plumbing.....	7
Step Three: Connect pump to vehicle battery.....	8
Step Four: Check and test completed assembly	9
Operation	
Important Safety Information - Operation	10
• General Chemical Safety	
• Chemical Applicator Safety	
• Chemical Accident Procedures	
Preparing the Pump for Each Use	14
Using the Pump	
Step One: Assess wind conditions and clear work area	15
Step Two: Operate the pump	15
Step Three: Clean pump and decontaminate after use	17
Storage	18
Preparing for storage	
Removing from storage	
Troubleshooting	19
Specifications	21
Parts Breakdown – Exploded View	22

Intended Use

The pump is intended for use in spraying agricultural pesticides and other non-flammable liquids.

SPRAYING PESTICIDES:

Pesticides are hazardous chemicals that must be handled with caution as directed throughout this manual and on the pesticide label. Pesticides are regulated by the United States Environmental Protection Agency (EPA) and defined as:

Any substance or mixture of substances intended for preventing, destroying, repelling, or mitigating any pest. Though often misunderstood to refer only to insecticides, the term pesticide is a comprehensive term that applies to insecticides, herbicides, fungicides, and various other substances used to control pests.

The pump is intended for use in spraying pesticides in liquid form only. The pump is NOT intended for use in spraying pesticides in dry or aerosolized form, or for use with fumigants.

SPRAYING OTHER LIQUIDS:

In addition to spraying pesticides, this pump may be used to spray other non-flammable liquids. Example uses include: watering plants/trees or spraying water for dust control, applying ice control chemicals, or applying water-based, non-flammable sealant or stain to outdoor wood surfaces.

However, **WE RECOMMEND THAT THE PUMP NOT BE USED FOR OTHER PURPOSES ONCE IT HAS ALREADY BEEN USED FOR SPRAYING PESTICIDES.** Any chemical will leave some residual in the pump, even after the pump has been properly cleaned. These residual chemicals can have unexpected effects on future uses. For example, spraying water or other liquids that are contaminated with residual pesticide may result in unforeseen hazards to plant or animal life.

Contact NorthStar Product Support at 1-800-270-0810 for any questions about the appropriate use of the pump and/or optional accessories.

Summary of Important Information

WARNING

Read and understand **this owner's manual** completely before using the pump. Read each **chemical label's instructions** before handling the chemical.

Improper use of the pump or handling of chemicals could result in serious injury or illness for the operator or nearby persons/animals, or cause damage to the environment.

LISTED BELOW is a summary of safety information of particular importance. See individual sections of this owner's manual for more details.

----- DURING ASSEMBLY -----

- **EXERCISE CAUTION** when attaching remote switch to battery terminals. Follow the steps listed in the Assembly section of this manual in *exact sequence* when connecting the pump to battery terminals. *Caution must be exercised to avoid contact with battery acid and to prevent sparking.*
- **CHECK and TEST completed assembly** as directed in this manual. Serious injury could result from chemical leaks if pump is improperly assembled.
- **DO NOT MODIFY pump design.**

-----DURING OPERATION-----

General Chemical Safety

- **READ and FOLLOW** each chemical label's instructions and warnings.
- **AVOID** inhaling, ingesting, or coming into contact with any chemicals.
- **KNOW** applicable licensing and regulatory requirements for the chemical you plan to use.
- **KNOW** emergency procedures before handling chemicals. Carefully review "Chemical Accident Procedures" listed below and later in this manual. Also see First Aid instructions on the chemical label.
- **WEAR** protective clothing, eye protection, and chemical resistant gloves when operating the pump. Wear additional protective gear, such as facemask or apron, as recommended on the chemical label.
- **EXERCISE EXTRA CAUTION** around children and pets. Pesticides are especially toxic to them. Keep pump and spray materials away from them at all times.
- **DO NOT MIX OR POUR** chemicals in an enclosed, unventilated area
- **DO NOT USE** flammable or corrosive chemicals in the pump.
- **FLUSH** the pump before switching chemicals in order to prevent dangerous chemical interactions.
- **STORE** pesticides in a correctly labeled container and in a secure location.
- **MONITOR** the health of operators frequently exposed to pesticides, as recommended by the chemical label or local/federal regulations.

Chemical Application Safety

Before Spraying

- **INSPECT and PREPARE** pump before each use as directed in this manual.
- **DO NOT TURN ON POWER to pump until ready to spray** in order to avoid unintentional spray release.
- **DO NOT SPRAY** when wind speed exceeds 4 MPH in order to minimize spray drift.
- **CLEAR** work area of people/ pets and **POST** warning notices to restrict access for the period recommended on chemical label.
- **KEEP** pump and spray materials away from children/pets. Pesticides can be especially toxic to children and animals.
- **DO NOT ALLOW** anyone younger than 16 to operate the pump since pesticides are especially toxic to children.

During Spraying

- **DO NOT OVERAPPLY** pesticide. Apply at rate recommended by chemical manufacturer. Excess pesticide can be dangerous to humans/animals, damage desirable plants, and contaminate soil and water sources.

Summary of Important Information

- **DO NOT EAT, DRINK, SMOKE, RUB YOUR EYES, or TOUCH YOUR BARE SKIN** while handling chemicals and spraying.
- **NEVER POINT A SPRAY GUN** at people or animals.
- **EXERCISE EXTRA CAUTION** when spraying near areas accessible to children and pets.
- **CLEAN up spills immediately** per instructions on the chemical label.
- **TURN OFF power to pump, and RELIEVE system pressure** before leaving pump unattended.
- **SEE Troubleshooting section of this manual before attempting any repairs.** Wear personal protective equipment and follow safety instructions.

After Spraying

- **CLEAN pump immediately after use** according to the directions provided in this manual.
- **DECONTAMINATE yourself after you are done spraying** and have cleaned the pump. Wash all exposed areas of the body with soap and water, and remove and launder clothing.
- **DISPOSE OF or STORE remaining chemicals in secure storage with correctly marked container.**

Chemical accident procedures

Immediate response is necessary in the event of pump leaks, bodily chemical contact, poisoning, or spills. See instructions below:

Pump leak	If the pump develops a leak, <i>immediately stop spraying.</i> Turn off power to the pump and follow directions below, as applicable.
Bodily chemical contact	<p>Personal contamination can occur when chemicals splash, spill, or spray directly onto a person.</p> <ol style="list-style-type: none"> 1. Immediately follow First Aid instructions on <u>chemical label</u>. <p style="margin-left: 20px;"><u>General procedures can include:</u></p> <ol style="list-style-type: none"> a) Eyes – immediately flush with water. b) Skin – wash all contaminated skin surfaces with soap and water. c) Clothing – remove contaminated clothing. Dispose of heavily contaminated clothing per chemical label instructions. 2. Seek medical advice if instructed on the label or the victim experiences symptoms of harmful effects. Bring the chemical label for reference.
Poisoning by ingestion or inhalation	<p>In case of poisoning from ingestion or inhalation:</p> <p><i>If the victim has collapsed or is not breathing, <u>call 911.</u></i> Otherwise:</p> <ol style="list-style-type: none"> 1. If you are the victim, immediately seek assistance from nearby personnel because you may become incapacitated. 2. Immediately follow first aid instructions on <u>chemical label</u>. 3. Call a poison control center for further advice. In the U.S., call 1-800-222-1222. Have the chemical label available for reference.
Chemical spills	<p>Chemical spills must be quickly contained and properly cleaned up.</p> <p>Refer to the chemical label for any specific clean-up instructions.</p> <p><u>General procedures include:</u></p> <ol style="list-style-type: none"> 1. Controlling the spill by stopping the source of the spill. 2. Containing the spill so that it does not spread and get into water sources. 3. Cleaning up the spill immediately. 4. Seeking additional advice from: <ul style="list-style-type: none"> - <u>Chemical manufacturer.</u> See chemical label for contact information. - <u>State pesticide regulatory agency.</u> In the U.S., call the National Pesticide Info. Ctr. at 800-858-7378 for assistance in contacting your state’s agency.

Installation

Step One: Mounting

- This NorthStar pump is self-priming.
- The pump should be located in an area that is dry and provides adequate ventilation.

CAUTION

DO NOT locate the motor near low temperature plastics or combustible material. The surface temperature of the motor may exceed 250°F [121°C].

- The pump may be mounted in any position. However, if mounting the pump vertically the pump head should be in the down position so that in the unlikely event of a leak, fluid will not enter the motor.
- Secure the rubber feet with #10 fasteners. **DO NOT** compress the feet, doing so will reduce their ability to isolate vibration/noise.

Step Two: Plumbing

- See table below for port size and recommended hose sizes. Use plastic male NPT (Tapered pipe thread) fittings (except 2681040) to connect flexible high-pressure tubing to the pump.

Pump Model	Ports	Minimum inlet hose size	Minimum outlet hose size
2681040	3/8" Hose barb	3/8" (9.5mm) Inside diameter	3/8" (9.5mm) Inside diameter
2682270	3/8" Female NPT	1/2" (13mm) Inside diameter	3/8" (9.5mm) Inside diameter
2683060	1/2" Female NPT	1/2" (13mm) Inside diameter	1/2" (13mm) Inside diameter
2684060	1/2" Female NPT	1/2" (13mm) Inside diameter	1/2" (13mm) Inside diameter
2685560	1/2" Female NPT	1/2" (13mm) Inside diameter	1/2" (13mm) Inside diameter

NOTE: NorthStar does not recommend the use of metal fittings or rigid pipe to plumb the inlet/outlet ports. Standard plastic threaded fittings are available by calling NorthStar Product Support at 1-800-270-0810.

- In some cases, the ports may require a suitable thread sealer applied sparingly. **DO NOT** over-tighten, maximum torque is 45 in/lb [5 N-m].
- Tubing should be compatible with the spraying fluid. At least 18" [450mm] length is suggested to minimize stress on the fitting/ports and reduce noise. Allow for the shortest possible tubing route and avoid sharp bends that may kink over time.
- Installation of a 50-mesh strainer is recommended to prevent foreign debris from entering the system. Failures due to foreign debris are not covered under the warranty.

NOTE: Restrictions on the inlet may cause a loss in performance. Inlet pressure must not exceed 30 psi [2.1 bar]

- If a check valve is installed in the plumbing, it must have a cracking pressure of no more than 2 psi [.14 bar].

CAUTION

Sealers and Teflon tape may act as lubricant causing cracked housings or stripped threads due to over tightening. Care should be used when applying sealers; it may enter the pump inhibiting valve action, causing no prime or no shut-off. Failures due to foreign debris are not covered under the warranty.

Installation (continued)

Step Three: Connect pump to battery or 12V supply

WARNING

Batteries are hazardous because they contain caustic acid, can emit explosive gases, and can cause electric shock.

Caution must be exercised when making connections to a battery to avoid shock and contact with the acid, and to prevent any sparking that could lead to an explosion.

ALWAYS follow the safety instructions and steps listed below *in exact sequence* when connecting the pump to the battery terminals.

1. Preparatory safety

Preparatory safety steps:

- ALWAYS use eye protection
- NEVER smoke or work near sparks or other sources of ignition.
- NEVER touch both battery terminals at the same time or with any non-insulated tools.
- If battery acid contacts skin or clothing, flush immediately with water and neutralize with baking soda.

2. CE requirements

- The pump should be on a dedicated (individual) circuit, controlled with a double pole switch (UL/CSA certified) rated at or above the fuse ampere indicated by the pump motor label. Depending on distance of the power source from the pump and ampere load on the circuit, wire may need to be heavier than indicated by the chart.
- For the pump to meet CE requirements the circuit **MUST** be **protected with a slow blow fuse** (UL/CSA certified) or equivalent circuit breaker as indicated on the motor label. Use an approved wire of the size specified or heavier.

Voltage	Model	Fuse (amp)	Wire Leads	Wire Size
12 VDC	2681040	10.0	RED (positive +) BLACK (negative -)	#14 AWG (2.5Mm ²) (or heavier)
12 VDC	2682270 2683060 2684060	15.0	RED (positive +) BLACK (negative -)	#14 AWG (2.5Mm ²) (or heavier)
12 VDC	2685560	20.0	RED (positive +) BLACK (negative -)	#14 AWG (2.5Mm ²) (or heavier)

3. Connect pump to battery

Connect the pump to a vehicle battery using the following procedure:

- a) Disconnect the vehicle battery ground wire.
- b) Connect the pump's **red** wire to the **positive (+)** terminal of the battery.
- c) Connect the pump's **black** wire to the **negative (-)** terminal of the battery.
- d) Reconnect the vehicle battery ground wire.

Note: Skip steps (a) and (d) if battery is not in a vehicle.

WARNING: Always connect in this sequence to avoid possible shock.

Installation (continued)

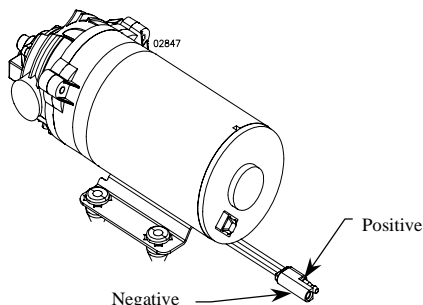

4. Disconnect after use

AFTER EACH USE, disconnect power to the pump using the following procedure:

- a) Disconnect the vehicle battery ground wire.
- b) Disconnect the pump's black wire from the **negative** (-) terminal of the battery.
- c) Disconnect the pump's red wire from the **positive** (+) terminal of the battery.
- d) Reconnect the vehicle battery ground wire.

Note: Skip steps (a) and (d) if battery is not in a vehicle.

WARNING: Always disconnect in this sequence to avoid possible shock.

NOTE: It is important to disconnect power to the pump when not in use for safety reasons. ALWAYS verify that the power has been disconnected before adding chemicals or servicing.

A remote switch is recommended for temporarily shutting off the pump's operation. Call NorthStar Product Support at 1-800-270-0810 to order NorthStar Item #250555 or #777493.

Step Four: Check and test completed assembly.

⚠ WARNING

Check and test completed assembly

Serious injury could result from chemical leaks if pump is improperly assembled or the design of the pump is modified.

Follow the steps below to ensure the pump is properly assembled. Never modify the pump design.

1. Check assembly

Check assembly to assure the pump is properly assembled and in safe working condition:

2. Test with water

Test the system for leaks with water:

- a) Fill the tank with water.
- b) The pump is an "on demand" pump. When turned on, the pump will prime itself, then turn off once reaching pressure. When the flow continues, the pump will automatically re-start.
- c) Check for leaks throughout the system. If a leak is detected, fix the leak and re-test the system with water.

Operation – Important Safety Information

Now that you have completed and tested your assembly, there is some important safety and health information you need to know with regard to handling and spraying chemicals.

WARNING

Carefully read and make sure you understand the following safety information before using the pump.

General Chemical Safety:

WARNING

Pesticides are hazardous chemicals.

Heed the warnings below and follow all instructions carefully.

Improper handling of chemicals can result in serious injury or illness, or cause damage to the environment.

- **Chemical label.** ALWAYS READ and FOLLOW all chemical label instructions.
- **Licensing/regulation.** Refer to any applicable licensing restrictions or state/federal regulations with regard to the application of the particular chemical you plan to use.
- **Emergency procedures.** Before handling chemicals, carefully review the “[Chemical Accident Procedures](#)” listed later in this section, as well as the “Statement of Practical Treatment” on the chemical label.
- **Inhalation/contact.** ALWAYS take precautions to avoid inhaling or coming into contact with the chemical.
- **Personal protective equipment.** ALWAYS wear protective clothing, eye protection, and chemical-resistant gloves when operating and cleaning the pump. Wear additional protective gear (such as facemask or apron) as recommended on the chemical label.
- **Children/pets.** Pesticides can be especially toxic to children and animals. ALWAYS exercise extra caution around children. Keep pump and all spray materials away from children and animals.
- **Ventilation.** ALWAYS ensure there is adequate ventilation when mixing, pouring, or spraying.
- **Flammables.** NEVER use any flammable chemicals in the pump.
- **Corrosives.** DO NOT use corrosive chemicals in the pump. They can weaken the pump and its parts, resulting in leaks. Check with the chemical manufacturer to ensure chemical is compatible with all components of the pump.
- **Chemical interaction.** ALWAYS flush the pump before switching chemicals. Different chemicals may interact dangerously with each other.
- **Chemical storage.** ALWAYS store pesticides in a properly labeled container and in a secure location per the manufacturer’s recommendations.
- **Health monitoring.** Monitor the health of operators who are frequently exposed to pesticides, as recommended by the chemical label or local/federal regulations.

Operation – Important Safety Information (continued)

Chemical Application Safety:

WARNING

Caution must be used when spraying chemicals to avoid unsafe exposure to humans and the environment.

Heed the warnings below and follow all instructions carefully.

Before Spraying

- **Pump prep.** ALWAYS inspect and prepare the pump before use according to the directions provided in this manual.
- **Keep pump off.** Do not turn on power to the pump until ready to spray in order to avoid unintentional spray release.
- **Wind speed.** NEVER spray when wind speed exceeds 4 MPH in order to minimize spray drift.
- **Clear area/post.** ALWAYS keep the work area clear of people and pets. POST warning notices to restrict access by the public for the period recommended on chemical label.
- **Operator age.** You must be 16 years of age or older to operate this pump. Pesticides are especially toxic to children.

During Spraying

- **Over application.** DO NOT over apply pesticide. Apply at a rate recommended by chemical manufacturer. Excess pesticide can be dangerous to humans, damage desirable plants, and contaminate soil and water sources.
- **Children/pets.** ALWAYS exercise extra caution when spraying near areas accessible to children and pets.
- **Eating/smoking.** DO NOT eat, drink, smoke, rub your eyes, or touch any part of your bare skin while handling chemicals and spraying.
- **Heat/flames.** DO NOT spray near open flames or sources of heat.
- **Spills.** ALWAYS clean up spills immediately per instructions on the chemical label.
- **Unattended.** ALWAYS turn off power to pump, and relieve system pressure before leaving pump unattended.
- **Troubleshooting.** ALWAYS refer to the safety instructions in the Troubleshooting Section before attempting any repairs.

After Spraying

- **Clean pump.** ALWAYS clean the pump immediately after use according to the directions provided in this manual.
- **Decontaminate.** ALWAYS decontaminate yourself immediately after you are finished spraying and handling chemicals. Wash all exposed areas of the body with soap and water and remove and launder clothing.
- **Chemical disposal/storage.** ALWAYS dispose of or store remaining chemicals properly as recommended on the chemical label.

Operation – Important Safety Information (continued)

Chemical accident procedures:

⚠ WARNING

Before you use the pump, review the following information with regard to handling accidents.

Chemical spills, pump leaks, personal contamination, and poisoning are accident situations which you may encounter.

All require an immediate response – See instructions below.

Pump leak	<p>In the event that the pump develops a leak while spraying chemicals, you must <i>immediately stop spraying.</i></p> <p style="padding-left: 20px;">Turn off power to the pump and follow the directions below, as applicable.</p>
Bodily chemical contact	<p>Personal contamination can occur when chemicals splash, spill, or spray directly onto a person.</p> <ol style="list-style-type: none"> 1. Follow the emergency first aid instructions on the chemical label listed in the “First Aid” or “Statements of Practical Treatment” section. <u>General procedures include:</u> <ol style="list-style-type: none"> a) Eyes – immediately flush with water or follow other directions as specified on the chemical label. b) Skin – immediately wash all contaminated skin surfaces with soap and water, or follow directions as specified on the chemical label. c) Clothing – remove contaminated clothing immediately. Dispose of heavily contaminated clothing per the instructions on the chemical label for safe chemical/container disposal. 2. Seek medical advice if instructed on the label, or if the victim experiences symptoms of harmful effects such as burning, swelling, nausea, chest pain, difficulty breathing, dizziness or confusion. When seeking medical advice, be sure to bring the chemical product label.
Poisoning by ingestion or inhalation	<p>In case of poisoning from ingestion or inhalation:</p> <p>IF THE VICTIM HAS COLLAPSED OR IS NOT BREATHING, <u>CALL 911.</u> Otherwise:</p> <ol style="list-style-type: none"> 1. If you are the victim, immediately seek assistance from nearby personnel because you may become incapacitated. 2. Follow the emergency first aid instructions on the chemical label in the “First Aid” or “Statement of Practical Treatment” section. 3. Call a poison control center for further advice. In the U.S., call 1-800-222-1222 to be automatically linked to the nearest certified poison control center. Have the chemical label available for reference.
Chemical spills	<p>Chemical spills must be quickly contained and properly cleaned up.</p> <p>Refer to the chemical label for any specific clean-up instructions with regard to the chemical spilled.</p>

Operation – Important Safety Information (continued)

General procedures include:

1. **Control** the spill by stopping the source of the spill. If the source of the spill is a container leak, place the leaking container in a larger, watertight container. Keep unprotected people away from the spill site.
2. **Contain** the spill so that it does not spread and get into water sources. Use a shovel or other tool to make a dike around the spill with soil, sod, or absorbent material.
3. **Clean up** the spill immediately -- Absorbent materials like ground corncobs or pet litter should be spread on the spill area to soak up the pesticide. The contaminated material should then shoveled into a leak proof container. Do not flush the spill area with water until you receive advice as directed below.
4. **Seek additional advice** from the chemical manufacturer and your state's pesticide regulatory agency regarding decontamination of the spill site:
 - *Chemical manufacturer.* The chemical label provides contact information for the chemical manufacturer.
 - *State pesticide regulatory agency.* In the U.S., call the National Pesticide Information Center at 1-800-858-7378 for assistance in determining how to contact your state's pesticide regulatory agency.

Operation – Preparing the Pump for Each Use

If the pump has been used previously, it must be prepared BEFORE EACH SUBSEQUENT USE.

WARNING

Read instructions below carefully for inspecting and preparing the pump.

Damaged or clogged equipment could result in leaks or uncontrolled spray.

Leaks could result in injury to the operator or bystanders from chemical exposure, or cause damage to the environment.

Important safety rules:

- **Power off.** Make sure all power is OFF before cleaning, inspecting, or servicing the pump.
- **Guards / shields.** Make sure all guards and shields are replaced after servicing the pump.
- **Replacement parts.** If a part needs replacement, only use parts that meet the manufacturer's specifications. Replacement parts that do not meet specifications may result in a safety hazard or poor operation of the sprayer.

1. Ensure clean system	Ensure the pump has been thoroughly flushed and drained of all residual chemicals from prior uses.
2. Inspect & repair	<p>Inspect and test the sprayer thoroughly:</p> <ul style="list-style-type: none"> a) Inspect hoses/ lines for exposed mesh and holes. Replace all worn or damaged hoses/ lines. b) Inspect fittings for cracks and leaks. Replace all damaged fittings with original NorthStar parts. c) Partially fill system with plain water and spray to test for leaks. Repair as needed. <p><i>IMPORTANT: After any repair work has been done, ALWAYS test for leaks with water one final time before using.</i></p>

Be certain the pump materials will be compatible with the chemical being pumped. NorthStar pumps are intended for intermittent or continuous duty when the proper operating criteria are met. If unsure of the chemical compatibility with the NorthStar pump components or the motors intended design, please call NorthStar Product Support at 1-800-270-0810 for assistance.

Operation – Using the Pump

Step One: Assess wind conditions and clear work area.

Before you decide to spray, you must determine whether wind conditions are suitable. You must also restrict access to the work area to ensure the safety of bystanders.

WARNING

Do not spray if wind speeds are greater than 4 MPH or if there are bystanders in the intended spray area.

1. Assess wind speed	<p>Assess weather conditions to ensure that it is not too windy to spray.</p> <p>DO NOT SPRAY if wind speeds are greater than 4 MPH.</p> <p><i>Visible indication of wind speed:</i> If leaves are in constant motion or there is any branch movement, DO NOT spray because the wind is too strong.</p>
2. Clear work area	<p>Clear the work area of all bystanders and pets.</p> <p>Restrict access by the public for the period recommended on chemical label.</p>

Step Two: Operate the pump.

WARNING

ALWAYS wear personal protective equipment as directed on the chemical label when spraying. Long pants and sleeves, chemical-resistant gloves, and eye protection are strongly recommended. Additional protective gear may be required depending on the particular pesticide.

1. Review safety information	<p>Review the “Operation – Important Safety Information” related to <u>Chemical Application Safety</u> provided in this manual.</p>
2. Wear personal protective equipment	<p>Wear personal protective equipment as directed on the chemical label.</p>
3. Turn on power	<p>Turn on the power to the pump.</p> <p><i>Note: The pump will start automatically when power is turned on. The pump will cycle on and off as needed to retain pressure in the hose.</i></p>

Operation – Using the Pump (continued)

4. Pressure Switch Operation	<p>The pressure switch reacts to outlet pressure, and interrupts power at the preset shut-off pressure indicated on the pump label. When outlet pressure drops below a predetermined limit the switch will close and the pump operates until the shut-off pressure is achieved. The shut-off pressure is set to factory calibrated standards.</p> <p><i>Note: If the plumbing is restrictive or the flow rate is very low, the pump may re-pressurize the outlet faster than the fluid is being released, causing rapid cycling (*ON/OFF within 2 seconds). If the pump is subjected to rapid cycling during normal operation, or for infrequent periods, damage may occur. Applications which exhibit rapid cycling should have restrictions in the outlet minimized.</i></p>
5. Leaving unattended	<p>If the pump must be left unattended at any time:</p> <ol style="list-style-type: none"> a) Disconnect power to the pump. b) Relieve system pressure.
6. Discontinue use if clogged or inoperative	<p>If the pump becomes clogged or inoperative during use, discontinue use immediately.</p> <ul style="list-style-type: none"> - DO NOT attempt to service while chemicals are in the pump and power is connected. - Return to service area to review instructions for troubleshooting before attempting to service.

CAUTION

DO NOT operate the pump at pressures which cause the motor to exceed the amperes rating indicated on the name plate.

Improper adjustment of the pressure switch setting may cause severe overload or premature failure. Failures due to improper adjustment for the pressure switch setting will not be covered under the warranty.

“Intermittent Duty” is defined as: operated and/or frequently started within a period of time that would cause the motor to reach its maximum thermal limits. Once the maximum thermal limit is obtained, the motor must be allowed to return to ambient temperature before resuming operation.

Note: A reserve, clean container capable of holding at least the volume of the entire pump system should be kept for use when the pump system needs to be emptied temporarily for repairs. It is advisable to purchase a reserve tank suitable for pesticide storage from Northern Tool and Equipment for use in these circumstances. The container should be properly labeled as to its contents if it is used.

Operation – Using the Pump (continued)

Step Three: Clean pump and decontaminate after use.

When done using the sprayer, it is important to clean the pump and decontaminate yourself. Do not store the pump when saturated with chemicals, as it is unsafe and could also result in damage to the equipment.

WARNING

Clean up and decontamination procedures must be followed after each use.

Improper equipment clean up and disposal of chemicals can result in dangerous chemical exposure to humans and the environment, as well as equipment damage.

Personal decontamination is required after spraying to minimize unsafe exposure to chemicals and potential illness.

1. Drain pump system	<p>If there is excess pesticide left in the pump system, drain the pump system:</p> <ul style="list-style-type: none"> a) Disconnect power to the pump and relieve system pressure. b) Find a suitable container in which to drain the unused pesticide. c) While wearing rubber gloves, eye protection, and all other required personal protective equipment, allow pesticide to drain into container.
2. Unused chemical	<p>Properly store or dispose of unused chemical:</p> <ul style="list-style-type: none"> a) <u>If the unused pesticide is to be stored for future use:</u> Store all unused pesticide in its original, or a suitably marked, container in a secure location out of the reach of children & animals. b) <u>If remaining pesticide is to be disposed:</u> Properly dispose of the remaining chemical and its container per the chemical manufacturer's recommendation and according to local hazardous waste disposal regulations.
3. Flush pump	<p>Flush the pump per the chemical manufacturer's recommendations. A general procedure is as follows:</p> <ul style="list-style-type: none"> a) Add fresh water to the pump system. b) Reconnect power to the pump. c) Operate the pump system and discharge all rinse water onto an area that can accept dilute pesticide application. d) Add 5 gallons of the chemical manufacturer's recommended cleaning solution. Operate the pump system, collecting the discharged solution if recommended by the manufacturer. e) After flushing, disconnect power to the pump and be sure all system pressure is relieved. f) Dispose of cleaning solution discharge as recommended by the manufacturer of the solution.
4. Decontaminate & launder	<p>Decontaminate yourself after you are finished handling chemicals:</p> <ul style="list-style-type: none"> a) Remove all clothing worn during spraying and chemical handling. b) Wash all exposed parts of the body with soap and water. c) Launder clothing separately from other wash.

Storage

Prepare the pump for end-of-season storage by running RV antifreeze through the system. This will keep internal parts lubricated, protect against corrosion, and keep the unit from freezing.

CAUTION

The pump will be damaged if it freezes.

Protect the pump from freezing during storage by following the instructions below.

Preparing for storage:

1. Add antifreeze	Pour RV antifreeze into the pump system. <i>Note: RV antifreeze is non-toxic and biodegradable and generally safer for the environment than automotive antifreeze.</i>
2. Spray briefly	Turn on the pump and run the pump system briefly until fluid sprays.

Removing from storage:

1. Drain	Drain the antifreeze left in the pump system into a suitable container.
2. Flush with water	Fill the pump system with fresh water and run through the system. Operate the pump system until the system is completely flushed. Be sure to set up containers to capture the antifreeze flush water.
3. Disposal	Dispose of the antifreeze and flush water properly.

Troubleshooting

WARNING

Before troubleshooting or attempting to service, read the following safety rules to avoid accidental exposure to chemical and also risk of electric shock.

Note: A reserve, clean container capable of holding at least the volume of the entire pump system should be kept for use when the pump system needs to be emptied temporarily for repairs. It is advisable to purchase a reserve tank suitable for pesticide storage from Northern Tool and Equipment for use in these circumstances. The container should be properly labeled as to its contents if it is used.

Before attempting to service the pump:

1. Personal protective equipment	Wear personal protective equipment as directed on the chemical label while servicing your pump.
2. Review troubleshooting table	Review the Troubleshooting Table below for the type of problem you are experiencing. However, DO NOT attempt to repair until the steps listed below are followed.
3. Empty and flush	If the cause listed for your problem is Clogged intake tube: empty the pump system and flush the pump with water as directed in the section, "Operation – Step Three". <i>- In order to avoid accidental exposure to chemicals, never attempt to unclog the intake tube until the pump system has been emptied and the pump flushed with water.</i>
4. Disconnect power/relieve pressure	Disconnect power to the pump and be sure all system pressure is relieved.
5. Perform repairs	Follow the directions provided in the troubleshooting table to repair the pump.
6. Test after servicing	After servicing, ALWAYS test the pump for leaks with plain water before using.

Troubleshooting (continued)

PROBLEM	CAUSE	SOLUTION
Pump will not turn on	Bad electrical connection	Check battery connections
	Short in wires	Check condition of wires
	Locked drive	Replace diaphragm assembly
	Faulty pressure switch	Replace pressure switch assembly
	Incorrect voltage	Check voltage ($\pm 10\%$)
Pump will not prime	Out of product	Refill supply container
	Inlet air leak	Tighten fittings/ Replace cracked fittings
	Inlet/ Outlet tube restriction	Remove restriction
	Incorrect voltage	Check voltage ($\pm 10\%$)
	Clogged intake valves	Remove obstruction
Low pressure/ flow	Clogged intake tube	Remove obstruction
	Worn wobble plate	Replace diaphragm assembly
	Worn diaphragm	Replace diaphragm assembly
	Worn pressure switch	Replace pressure switch assembly
	Inlet/ Outlet tube restriction	Remove restriction
	Incorrect voltage	Check voltage ($\pm 10\%$)
	Clogged intake valves	Remove obstruction
	Clogged intake tube	Remove obstruction
Pump leaks	Inlet air leak	Tighten fittings/ Replace cracked fittings
	Loose fasteners	Tighten fasteners
	Pump seals degraded	Replace pump head assembly
	Leak in diaphragm	Replace diaphragm assembly
Pump cycles while not spraying	Leak in the system	Tighten leaking hose clamps/ fittings
	Faulty pressure switch	Replace pressure switch assembly
	Incorrect voltage	Check voltage ($\pm 10\%$)
	Air trapped in system	Purge the air from the system
Rough operation	Flexible mounting surface	Mount pump on rigid surface
	Loose pump head	Tighten fasteners
	Compressed base feet	Decompress base feet
	Rigid plumbing	Plumb pump with flexible plumbing

Specifications

Pump Model Number	2681040	2682270	2683060	2684060	2685560
Electrical connection	12 VDC	12 VDC	12 VDC	12 VDC	12 VDC
Maximum amp draw	4.0 Amps	7.5 Amps	10 Amps	13 Amps	17 Amps
Maximum flow	1.0 GPM [3.8 LPM]	2.2 GPM [8.3 LPM]	3.0 GPM [11.4 LPM]	4.0 GPM [15.1 LPM]	5.5 GPM [20.8 LPM]
Maximum pressure	40 PSI [2.8 bar]	70 PSI [4.8 bar]	60 PSI [4.1 bar]	60 PSI [4.1 bar]	60 PSI [4.1 bar]
Ports	3/8" Hose barb	3/8" Female NPT	1/2" Female NPT	1/2" Female NPT	1/2" Female NPT
Overall dimensions	7"x 4"x 2.5" [178mm x 102mm x 64mm]	9"x 4"x 4" [230mm x 102mm x 102mm]	9"x 5.5"x 5" [230mm x 140mm x 127mm]	9"x 5.5"x 5" [230mm x 140mm x 127mm]	9"x 5.5"x 5" [230mm x 140mm x 127mm]
Weight	1.5 lb [0.7 kg]	5 lb [1.8 kg]	6 lb [2.7 kg]	6 lb [2.7 kg]	6 lb [2.7 kg]

Component Materials*

Pump Head.....	Polypropylene, Viton [®] , Stainless Steel
Diaphragm.....	Santoprene [™]
Valves.....	Viton [®] , Polypropylene

*Before using any chemical, check to ensure the chemical is compatible with all materials in the system.

The manufacturer reserves the right to make improvements in design and/or changes in specifications at any time without incurring any obligation to install them on units previously sold.

Any Questions, Comments, Problems or Parts Orders
Call NorthStar Product Support 1-800-270-0810

Exploded View – 2682270 – Rev E

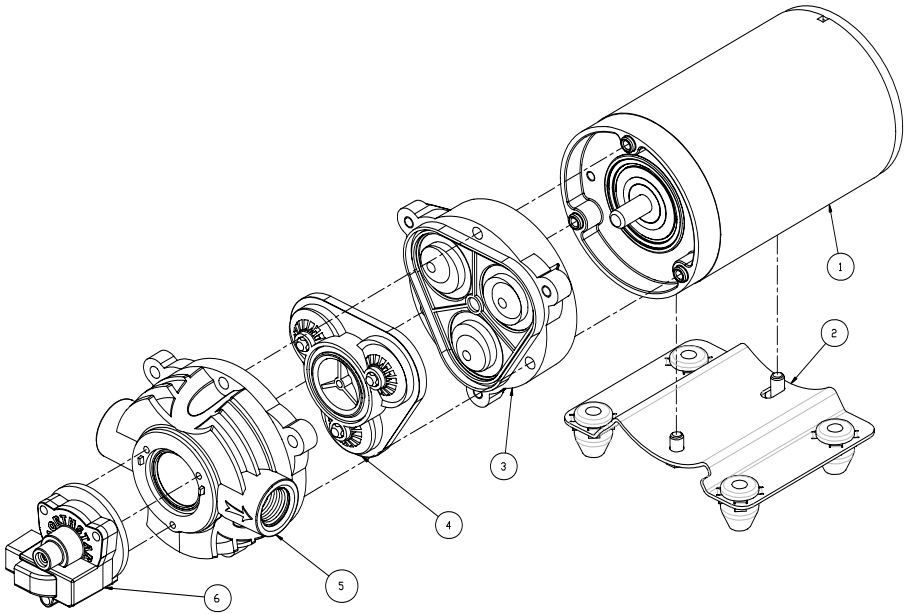

Item	Part#	Description	Qty
1	778306	Motor	1
2	780254	Base plate assembly	1
3	778747	Diaphragm assembly	1
4	778279	Valve plate assembly	1
5	780253	Pump head assembly	1
6	785294	Pressure switch assembly	1

Exploded View – 2683060, 2684060, & 2685560 – Rev E

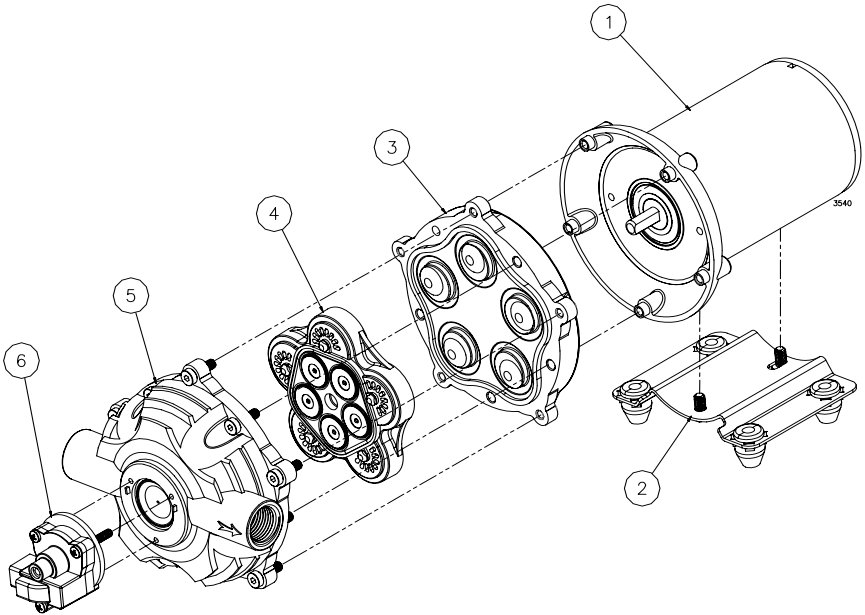

Item	Part#	Description	Model	Qty
1	780502	Motor	All	1
2	780254	Base plate assembly	All	1
3	781863	Diaphragm assembly	2683060	1
	781864		2684060	
	780505		2685560	
4	780509	Valve plate assembly	All	1
5	780515	Pump head assembly	All	1
6	785293	Pressure switch assembly	All	1



Manufactured by
Northern Tool + Equipment Co.,
2800 SouthCross Drive West
P.O. Box 1499 Burnsville, MN 55337-0499