

#188203

## HS-7A-2 PNEUMATIC WHEEL

### ASSEMBLY INSTRUCTIONS

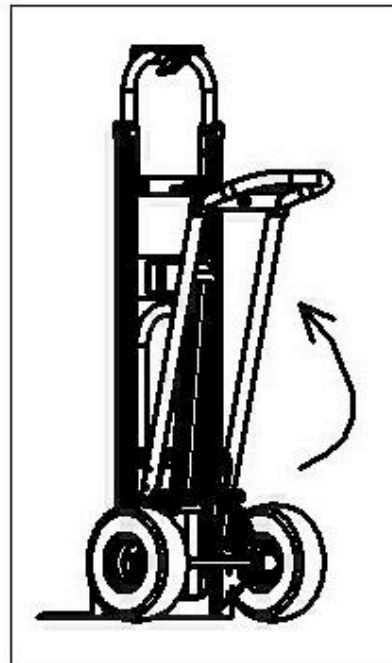
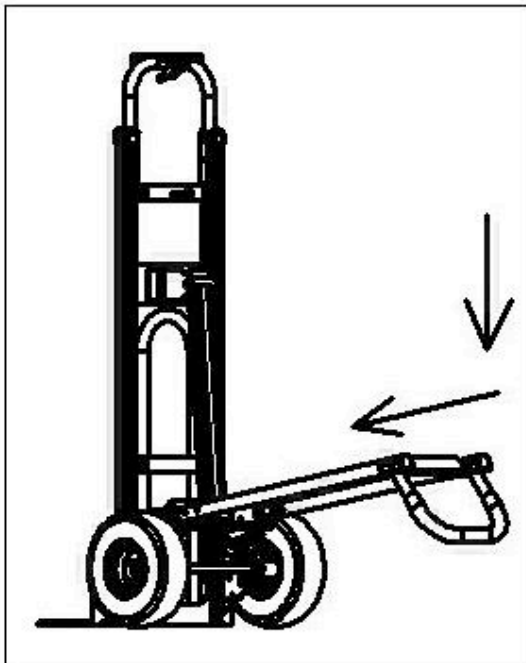
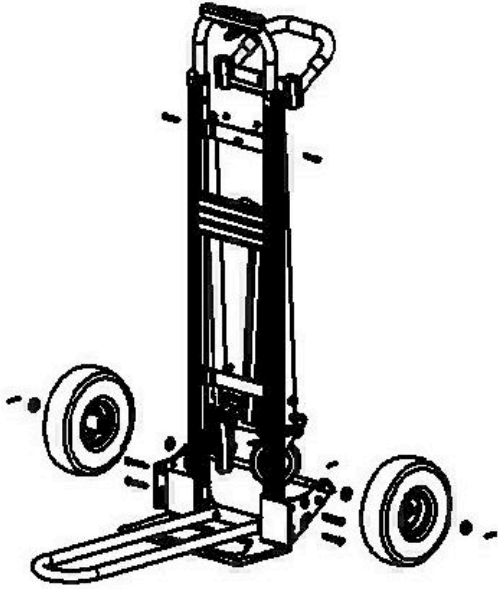

Assembly of your Hand Truck will be FASTER and EASIER if you

- Read instructions thoroughly before proceeding.

- Sort connection hardware into separate piles before assembling
- Tighten all parts by hand. Don't use power tools
- Don't over load as components could be damaged

1. Slide down the loop handle on the top of the frame, secure with bolts and nuts.

2. Place nose plate on the floor, and then slide the end of the nose plate to frame, at the same time, attach the two wheel brackets to the exterior on the bottom end of the frame on both sides. Align holes on the wheel brackets, frame and nose plate, then insert bolts through holes on both sides and fasten with locknuts

**NOTE: DO NOT TIGHTEN** locknuts until you completed step No.3

3. Insert axle through holes of the wheel brackets, add a washer on each side of the axle and then put wheels on the axle. Add another washer, then secure with cotter pin. Repeat sequence for the other side.

4. Tighten all locknuts in Step No.2.

HAND TRUCK IS NOW READY TO USE

Made in Taiwan