



# GENERAC® GUARDIAN® SERIES STANDBY GENERATORS

## 60 kW

### Liquid-Cooled Engine Generator Sets

Standby Power Rating

Model QT060 (Steel - Bisque) - 60 kW 60Hz

Model QT060 (Aluminum - Gray) - 60 kW 60Hz

#### INCLUDES:

- Generac Turbocharged/Aftercooled Gaseous Fueled 2.4L Engine
- Two Line LCD Tri-lingual Digital Nexus™ Controller
- Isochronous Electronic Governor
- Sound Attenuated Enclosure
- Closed Coolant Recovery System
- Smart Battery Charger
- UV/Ozone Resistant Hoses
- ±1% Voltage Regulation
- Natural Gas or LP Operation
- 2 Year Limited Warranty
- UL 2200 Listed



QUIET-TEST™

Meets EPA Emission Regulations  
Not for sale in CA/MA

## FEATURES

- **INNOVATIVE DESIGN & PROTOTYPE TESTING** are key components of GENERAC'S success in "IMPROVING POWER BY DESIGN." But it doesn't stop there. Total commitment to component testing, reliability testing, environmental testing, destruction and life testing, plus testing to applicable CSA, NEMA, EGSA, and other standards, allows you to choose GENERAC POWER SYSTEMS with the confidence that these systems will provide superior performance.
- **TEST CRITERIA:**
  - ✓ PROTOTYPE TESTED
  - ✓ SYSTEM TORSIONAL TESTED
  - ✓ NEMA MG1-22 EVALUATION
  - ✓ MOTOR STARTING ABILITY
- **SOLID-STATE, FREQUENCY COMPENSATED VOLTAGE REGULATION.** This state-of-the-art power maximizing regulation system is standard on all Generac models. It provides optimized FAST RESPONSE to changing load conditions and MAXIMUM MOTOR STARTING CAPABILITY by electronically torque-matching the surge loads to the engine. An unequalled ±1% voltage regulation.
- **SINGLE SOURCE SERVICE RESPONSE** from Generac's extensive dealer network provides parts and service know-how for the entire unit, from the engine to the smallest electronic component.
- **GENERAC TRANSFER SWITCHES.** Long life and reliability are synonymous with GENERAC POWER SYSTEMS. One reason for this confidence is that the GENERAC product line includes its own transfer systems and controls for total system compatibility.



## GENERATOR SPECIFICATIONS

TYPE	Synchronous
ROTOR INSULATION	Class H
STATOR INSULATION	Class H
TELEPHONE INTERFERENCE FACTOR (TIF)	< 50
ALTERNATOR OUTPUT LEADS 3 PHASE	4 wire
BEARINGS	Sealed Ball
COUPLING	Flexible Disc
LOAD CAPACITY (STANDBY RATING)	60 kW
EXCITATION SYSTEM	Direct

## VOLTAGE REGULATION

TYPE	Electronic
SENSING	Single Phase
REGULATION	± 1%

## GENERATOR FEATURES

Revolving field heavy duty generator  
 Directly connected to the engine  
 Operating temperature rise 120 °C above a 40 °C ambient  
 Insulation is Class H rated at 150 °C rise  
 All models are fully prototyped tested

## ENCLOSURE FEATURES

Galvanized steel weather protective enclosure	Ensures protection against mother nature. Electrostatically applied textured epoxy paint for added durability.
Enclosed critical grade muffler	Quiet, critical grade muffler is mounted inside the unit to prevent injuries.
Small, compact, attractive	Makes for an easy, eye appealing installation.
SAE	Sound attenuated enclosure ensures quiet operation.

## ENGINE SPECIFICATIONS

MAKE	Generac
MODEL	In line
CYLINDERS	4
DISPLACEMENT	2.4 Liter, 146 in. <sup>3</sup>
BORE	3.41
STROKE	3.94
COMPRESSION RATIO	8.5:1
INTAKE AIR SYSTEM	Turbocharged/Aftercooled
VALVE SEATS	Hardened
LIFTER TYPE	Hydraulic

## GOVERNOR SPECIFICATIONS

TYPE	Electronic	
FREQUENCY REGULATION	Isochronous	
STEADY STATE REGULATION	± 0.25%	
ADJUSTMENTS FOR		
	Speed	Yes
	Drop	Yes

## ENGINE LUBRICATION SYSTEM

OIL PUMP	Gear
OIL FILTER	Full flow spin-on cartridge
CRANKCASE CAPACITY	4 Quarts

## ENGINE COOLING SYSTEM

TYPE	Closed
WATER PUMP	Belt driven
FAN SPEED	2100
FAN DIAMETER	22 inches
FAN MODE	Puller

## FUEL SYSTEM

FUEL TYPE	Natural gas, propane vapor
CARBURETOR	Down Draft
SECONDARY FUEL REGULATOR	Standard
FUEL SHUT OFF SOLENOID	Standard
OPERATING FUEL PRESSURE	5" - 14" H <sub>2</sub> O

## ELECTRICAL SYSTEM

BATTERY CHARGE ALTERNATOR	12V 30 Amp
STATIC BATTERY CHARGER	2 Amp
RECOMMENDED BATTERY	Group 26, 525CCA
SYSTEM VOLTAGE	12 Volts

<b>OPERATING DATA</b>			
<b>KW RATING (LP/NG)</b>	60/60		
<b>ENGINE SIZE</b>	2.4 Liter 4 cyl. inline		
<b>GENERATOR OUTPUT VOLTAGE/KW - 60Hz</b>	<b>KW</b>	<b>AMP</b>	<b>CB Size</b>
120/240V, 1-phase, 1.0 pf	60	250	300
120/208V, 3-phase, 0.8 pf	60	208	250
120/240V, 3-phase, 0.8 pf	60	180	200
277/480V, 3-phase, 0.8 pf	60	90	100
<b>ENGINE FUEL CONSUMPTION (Natural Gas) (Propane)</b>	<b>Natural Gas</b> (ft <sup>3</sup> /hr.)		<b>Propane</b> (gal/hr.)      cu ft/hr
Exercise cycle	123		1.34      49.3
25% of rated load	267		2.7      101
50% of rated load	483		5.0      183
75% of rated load	672		7.0      255
100% of rated load*	862		9.0      327
For Btu content, multiply ft <sup>3</sup> /hr x 2520 (LP) or ft <sup>3</sup> /hr x 1000 (NG)			
<b>ENGINE COOLING</b>			
Air flow (inlet air including alternator and combustion air)	ft <sup>3</sup> /min.	3,280	
System coolant capacity	US gal.	2.5	
Heat rejection to coolant	BTU/hr.	270,000	
Max. operating air temp. on radiator	°C (°F)	60 (150)	
Max. ambient temperature	°C (°F)	50 (140)	
<b>COMBUSTION AIR REQUIREMENTS</b>			
Flow at rated power 60 Hz	cfm	180	
<b>SOUND EMISSIONS IN DBA</b>			
Exercising at 7 meters		65	
Normal operation at 7 meters		72	
<b>EXHAUST</b>			
Exhaust flow at rated output 60 Hz	cfm	494	
Exhaust temp. at muffler outlet	°F	1,050	
<b>ENGINE PARAMETERS</b>			
Rated synchronous RPM	60 Hz	3600	
<b>POWER ADJUSTMENT FOR AMBIENT CONDITIONS</b>			
Temperature Deration	3% for every 10 °C above - °C 1.65% for every 10 °F above - °F	25 77	
Altitude Deration	1% for every 100 m above - m 3% for every 1000 ft. above - ft.	915 3000	

\* Refer to "Emissions Data Sheets" for maximum fuel flow for EPA and SCAQMD permitting purposes.

**RATING:** All three phases units are rated at 0.8 power factor. All single phase units are rated at 1.0 power factor. **STANDBY RATING:** Standby ratings apply to installations served by a reliable utility source. The standby rating is applicable to varying loads for the duration of a power outage. There is no overload capability for this rating. Ratings are in accordance with ISO-3046-1. Design and specifications are subject to change without notice.  
KW rating is based on LPG Fuel and may derate with natural gas.

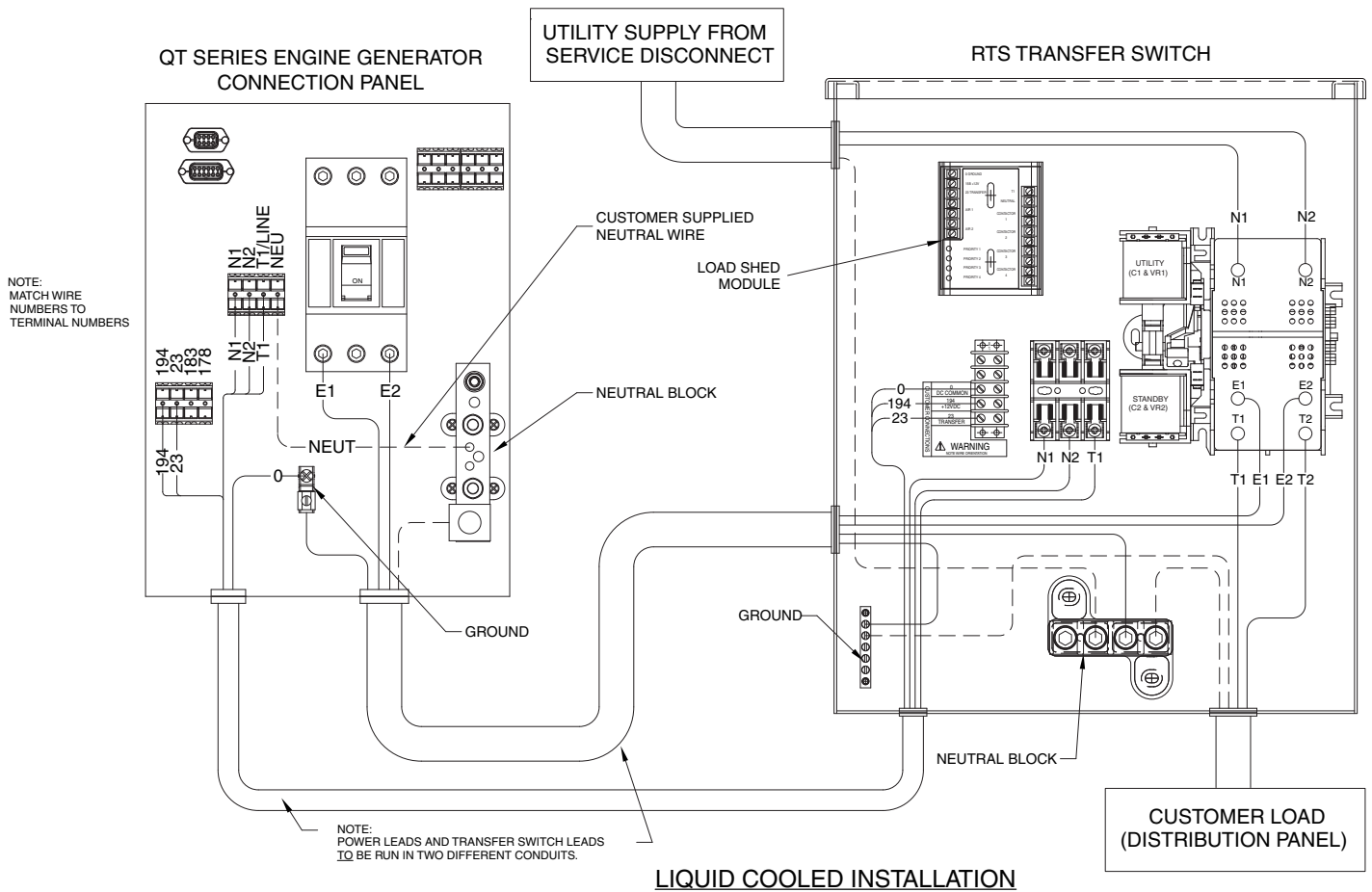

## NEXUS™ CONTROL FEATURES

2-Line Plain Text LCD Display	Simple user interface for ease of operation
Mode Switch	Automatic Start on Utility failure. 7 day exerciser
-Auto	
-Off	Stops unit. Power is removed. Control and charger still operate.
-Manual/Test (start)	Start with starter control, unit stays on. If utility fails, transfer to load takes place.
Programmable start delay between 10-30 seconds	Standard
Engine Start Sequence	Cyclic cranking: 16 sec. on, 7 rest (90 sec. maximum duration)
Engine Warm-up	5 seconds
Engine Cool-Down	1 minute
Starter Lock-out	Starter cannot re-engage until 5 sec. after engine has stopped.
Smart Battery Charger	Standard
Automatic Voltage Regulation with Over and Under Voltage Protection	Standard
Automatic Low Oil Pressure Shutdown	Standard
Overspeed Shutdown	Standard, 72Hz
High Temperature Shutdown	Standard
Overcrank Protection	Standard
Safety Fused	Standard
Failure to Transfer Protection	Standard
Low Battery Protection	Standard
50 Event Run Log	Standard
Future Set Capable Exerciser	Standard
Incorrect Wiring Protection	Standard
Internal Fault Protection	Standard
Common External Fault Capability	Standard
Governor Failure Protection	Standard

\*Single and three phase connections may vary , refer to the owner's manual for specific connection information.

SERVICE ITEM	2. 4L
OIL FILL CAP	THRU RIGHT DOOR
OIL DIP STICK	THRU RIGHT DOOR
OIL FILTER	THRU LEFT DOOR
OIL DRAIN HOSE	THRU RIGHT DOOR
RADIATOR DRAIN HOSE	THRU LEFT DOOR
AIR CLEANER ELEMENT	THRU LEFT DOOR
SPARK PLUGS	THRU LEFT DOOR
MUFFLER	SEE NOTE 6
FAN BELT	SEE NOTE 6
BATTERY	THRU LEFT DOOR

REFERENCE OWNERS MANUAL FOR PERIODIC REPLACEMENT PART LISTINGS

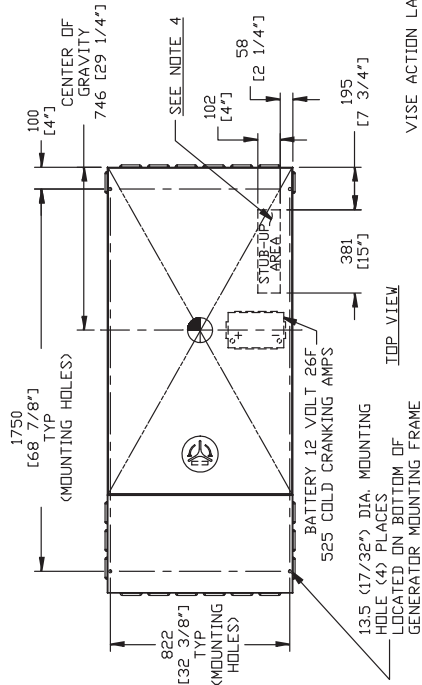

13.5 (17/32\") DIA. MOUNTING HOLE (4) PLACES LOCATED ON BOTTOM OF GENERATOR MOUNTING FRAME

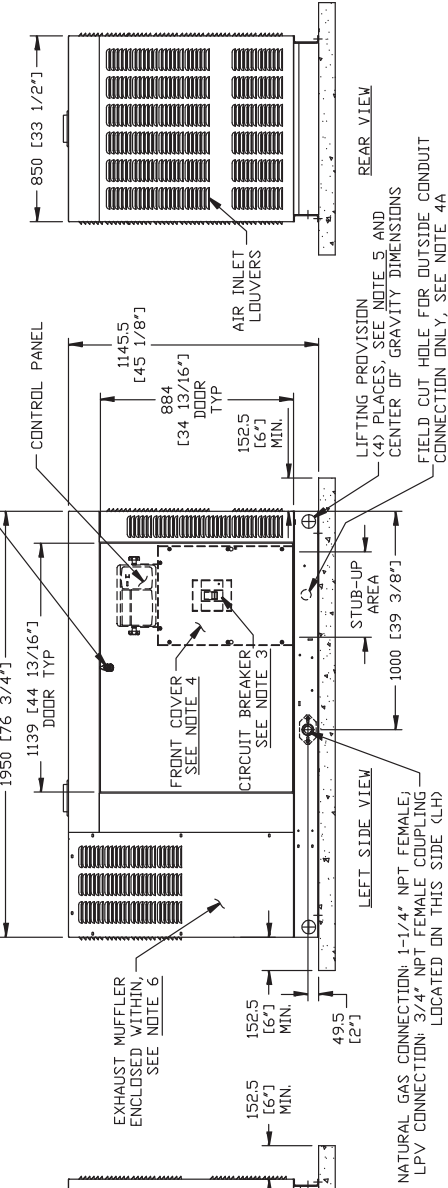

EXHAUST AND AIR DISCHARGE LOUVERS - FRONT AND SIDES

13.5 (17/32\") DIA. MOUNTING HOLE (4) PLACES, 12.7 (1/2\") DIA. MASONRY ANCHOR BOLTS RECOMMENDED

CONCRETE MOUNTING PAD (SEE NOTE 1)

ENCLOSURE MATERIAL	WEIGHT DATA	
	WEIGHT (GENSET ONLY) KG (LBS)	WEIGHT (FRAMING AND GENSET) KG (LBS)
STEEL	654 [1441]	44 [981]
ALUMINUM	600 [1324]	44 [981]

### NOTES:

- 1) MINIMUM RECOMMENDED CONCRETE PAD SIZE: 1155 (45 1/2\") WIDE X 2255 (88 7/8\") LONG. REFERENCE INSTALLATION GUIDE SUPPLIED WITH UNIT FOR CONCRETE PAD GUIDELINES.
- 2) ALLOW SUFFICIENT ROOM ON ALL SIDES OF THE GENERATOR FOR MAINTENANCE AND SERVICING. THIS UNIT MUST BE INSTALLED IN ACCORDANCE WITH CURRENT APPLICABLE NFPA 37 AND NFPA 70 STANDARDS AS WELL AS ANY OTHER FEDERAL, STATE AND LOCAL CODES FOR MINIMUM DISTANCES FROM OTHER STRUCTURES.
- 3) CIRCUIT BREAKER INFORMATION: SEE SPECIFICATION SHEET WITHIN OWNERS MANUAL
- 4) INSIDE STUB-UP AREA FOR AC LOAD LEAD CONDUIT CONNECTION, NEUTRAL CONNECTION, BATTERY CHARGER 120 VOLT AC (0.5 AMP MAX.) CONNECTION, AND ACCESS TO TRANSFER SWITCH CONTROL WIRES. REMOVE FRONT COVER FOR ACCESS.
- 4A) FIELD CUT HOLE IS ONLY REQUIRED FOR MOUNTING OF GENERATOR ON AN EXISTING PAD.
- 5) REFERENCE OWNERS MANUAL FOR LIFTING WARNINGS.
- 6) REMOVE EITHER LEFT OR RIGHT HAND SIDE PANEL TO ACCESS EXHAUST MUFFLER AND FAN BELT.

NATURAL GAS CONNECTION: 1-1/4\"/>

<b>Model #</b>	<b>Product</b>	<b>Description</b>
5630	Cold Weather Kit	If the temperature regularly falls below 32° F, install a cold weather kit to maintain optimal battery temperature. Kit consists of battery warmer with thermostat built into the wrap.
5616	Extreme Cold Weather Kit	Recommended where the temperature regularly falls below 32° F for extended periods of time. For liquid cooled units only.
5651	Base Plug Kit	Add base plugs to the base of the generator to keep out debris.
5703	Paint Kit	Bisque Kit
5984	Scheduled Maintenance Kit	The Liquid-Cooled Scheduled Maintenance Kits offer all the hardware necessary to perform a complete maintenance on Generac liquid-cooled generators.
5928	Nexus Wireless Remote	Completely wireless and battery powered, Generac's Nexus wireless remote monitor provides you with instant status information without ever leaving the house.
5951	Advanced Nexus Wireless Remote	Remotely control generator functions with the advanced model's LCD display. In addition to remote testing of the generator, set the exercise cycle and maintenance interval reminders
5937	DLM Load Control Module (50 Amps)	DLM Modules are used in conjunction with the Nexus Smart Switch to increase its load management capabilities. It gives the Nexus Smart Switch additional load management flexibility not found in any other transfer switch.