



PROCESSES

Both Models:



Flux Cored (FCAW) Welding

Handler 125 MIG (or Handler 125 with optional MIG Kit installed):



MIG (GMAW) Welding

5/3/1 INDUSTRIAL WARRANTY

MADE IN **USA**



Handler 125

The Handler 125 is a rugged constant-voltage DC welder with built-in wire feeder, that operates off 115-volt household current. It comes ready to weld, without shielding gas, using .030-.035 in (0.8-0.9 mm) self-shielding flux cored wire. This is a great unit for outdoor applications when shielding gas could be blown away. Welds up to 3/16 in steel with flux-cored wire.

For greater versatility, consider the Handler 125 MIG (or upgrade a Handler 125 with the optional MIG kit). This unit has a solenoid valve installed for welding with .023-.030 in (0.6-0.8 mm) solid wire and gas

shielding. Use C-25 gas (75% Argon/25% CO₂) on 22 gauge - 1/8 in steel for a cleaner weld with less spatter. Use Tri-Mix gas and stainless wire for welding on 16-12 gauge stainless steel.

Comes Complete With:

- Comfortable H-9A gun, 8 ft (2.4 m) with liner for .023-.035 in (0.6-0.9 mm) diameter wire
- Three .030 in (0.8 mm) contact tips
- Work clamp with 10 ft (3 m) work cable
- 1 lb spool of .030 in (0.8 mm) self-shielding flux cored wire
- Spool shaft to accommodate 4 in spools. (Optional hub kit available for 8 in spools.)
- Power cord with plug
- Weld set-up chart
- Owner's manual with parts lists, installation, operation, maintenance and wire welding guidelines
- The Handler 125 MIG also includes a gas solenoid (installed), Argon-mix regulator and 5 ft gas hose

Applications

- Farm/Home
- Light Maintenance and Repair
- Light Fabrication

FEATURES

BENEFITS

Broad output range of 30 - 125 A	Allows you to weld up to 3/16 in steel with flux cored wire.
Four output voltage settings with wire feed speed tracking	Provides a broader operating window for each wire, with quick and easy adjustment for different thicknesses and joints.
Built-in contactor	Eases use and excellent safety feature which makes wire electrically "cold" until trigger is pulled.
Durable feed head with quick-release drive roll tension lever	Positive feed with adjustable tension plus easy accessibility to thread new wire.
Dual-groove quick-change drive roll	Makes it easy to change from one wire size to another. One knurled groove for .030-.035 in (0.8-0.9 mm) wire, and one smooth groove for .023/.025 in (0.6 mm) wire.
Primary circuit breaker	Protects unit against current overload.
Self-resetting thermal overload	Protects power transformer to ensure reliability.
Self-resetting motor protection	Protects wire feed system from overload, no fuses to change or circuit breaker buttons to reset.
Upgradeable for welding with gas	Easy-to-install MIG Conversion Kit available (for Handler 125 only).
Convenient polarity changeover with spare tip holder	Access makes it quick and easy to change polarity for solid or flux cored wire plus convenient storage holes for spare tips.
Separate "Fan Only" or "Purge" setting	With gas solenoid installed, this position permits purging of the gas line and setting of flow rate without wasting wire
Hobart's 5/3/1 Industrial Warranty	Five-year warranty on transformers, three years on electronics (drive motors, rectifiers) and one year on guns.

SPECIFICATIONS (SUBJECT TO CHANGE WITHOUT NOTICE.)

DC **CV** **1**
Phase

Rated Output	Current Range	Max. Open-Circuit Voltage	Wire Feed Speed Range	Amps Input at Rated Output, 60 Hz, 1-Phase			Dimensions	Net Weight
				115 V	KVA	KW		
90 A, 19 VDC, at 20% Duty Cycle 63 A, 21 VDC at 20% Duty Cycle*	30-125 A	29 V	0-415 IPM (0-11 MPM) 0-500 IPM (0-13 MPM) at no load	20	2.9	2.5	H: 16-7/8 in (429 mm) W: 9-7/8 in (251 mm) D: 12-1/8 in (308 mm)	50 lb (22.7 kg)
				15*	2.2*	1.77*		

* Certified to both the Canadian and U.S. Standards for welding equipment.



Hobart Welders An Illinois Tool Works Company

U.S. Distributor Sales Phone 920-735-4576 FAX 800-637-2315
 Hobart Retail Sales Phone 800-332-3281 FAX 937-332-4161
 Canadian Sales Phone 888-489-9353 FAX 519-421-0480
 International Sales Phone 920-735-4509 FAX 920-735-4125

Web Site HobartWelders.com



CONTROL PANEL

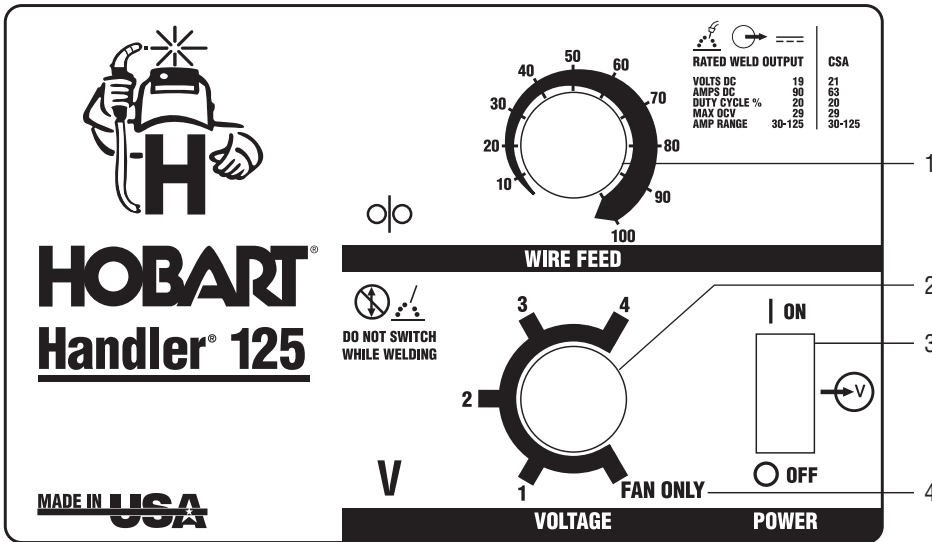

1. Wire Speed Control
2. Voltage Control Switch
3. Power Switch
4. "Fan Only" Position

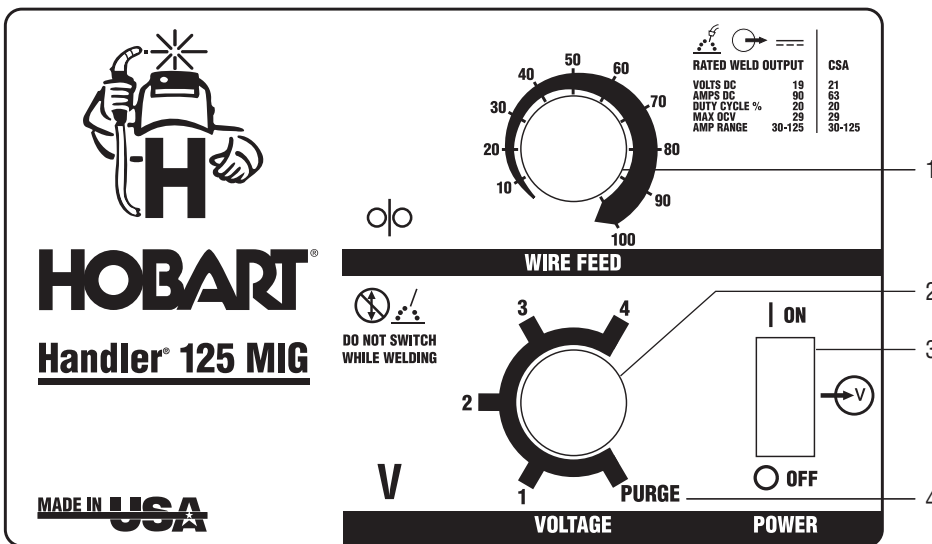

1. Wire Speed Control
2. Voltage Control Switch
3. Power Switch
4. "Purge" Position

PERFORMANCE DATA

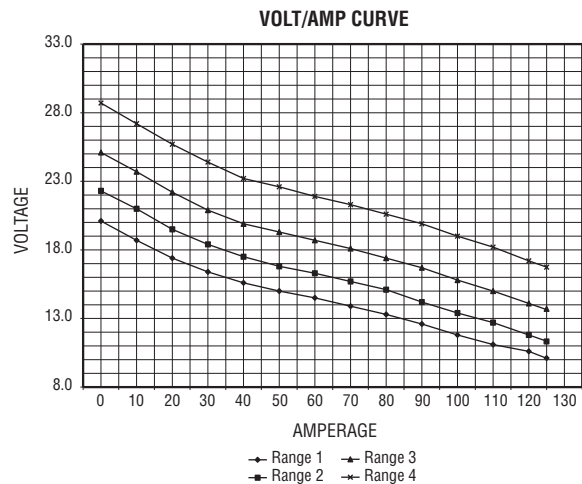
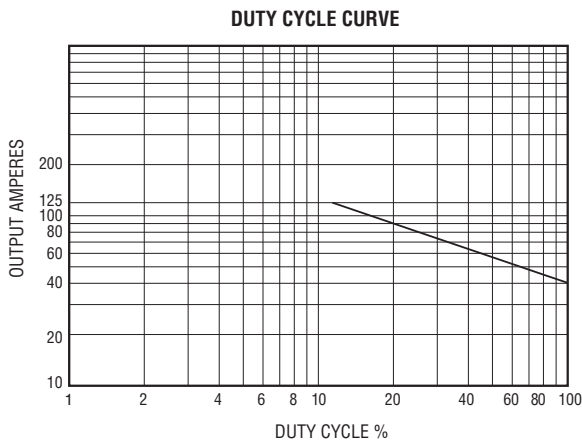

ACCESSORIES



MIG Conversion Kit #195158

For Handler 125 only. Includes regulator, 5 ft (1.5 m) gas hose, solenoid valve and connecting leads, hose adapter, three .023/.025 in contact tips, one spool of .024 (0.6 mm) ER70S-6 solid wire, and installation instructions.

Hub Kit #195216

For using 8 in (51 mm) spools.



Small Running Gear/Cylinder Rack #194776

Durable construction. For gas cylinders no larger than 7 in (178 mm) diameter, maximum weight 75 lb (34 kg).



Running Gear/Cylinder Rack #770187

Heavy-duty construction. For gas cylinders no larger than 7 in (178 mm) diameter, maximum weight 100 lb (45 kg).



Protective Cover #195186

Weather-resistant nylon resists stains and mildew, and protects the finish of your welder.

Replacement Drive Roll #212379

Dual-groove, one smooth groove for .023/.025 in (0.6 mm) wire and one knurled groove for .030-.035 in (0.8-0.9 mm) wire.

H-9A Replacement MIG Gun #195343

Comes in 8 ft (2.4 m) length with liner, for .023-.035 in (0.6-0.9 mm) diameter wire.

CONSUMABLES

Item	Hobart Package Part #*	Miller Package Part #**
Contact Tips		
.023/.025 in (0.6 mm)	#196134 (5 per package)	#087 299 (10 per package)
.030 in (0.8 mm)	#196131 (5 per package)	#000 067 (10 per package)
.035 in (0.9 mm)	#196132 (5 per package)	#000 068 (10 per package)
Nozzles	#196137	#169 715
Tip Adapter	#196135	#169 716
Liner	#210970R	—

*Available at farm and tool supply retailers.

**Available at Hobart/Miller welding distributors.

ORDERING INFORMATION AND SYSTEM CHECKLIST

Power Source	Stock No.	Description	Qty.	Price
Handler 125	#500487	115 VAC flux cored wire welding package		
UPC: #715959298711; Shipping Weight: 55 lb (25 kg); Carton Dimensions: 29 x 11 x 14 in (736 x 279 x 355 mm); Pallet Qty: 12; Pallet Dimensions: 30 x 46 x 44 in (762 x 1168 x 1118 mm)				
Handler 125 MIG	#500495	Includes gas solenoid, regulator and 5 ft gas hose		
UPC: #715959304801; Shipping Weight: 58 lb (26.4 kg); Carton Dimensions: 29 x 11 x 14 in (736 x 279 x 355 mm); Pallet Qty: 12; Pallet Dimensions: 30 x 46 x 44 in (762 x 1168 x 1118 mm)				
Accessories				
MIG Conversion Kit	#195158	Includes regulator, 5 ft (1.5 m) gas hose, solenoid valve and connecting leads, hose adapter, 3 contact tips (.023/.025 in), 2 lb spool of ER70S-6 solid wire, and install instructions		
Hub Kit	#195216	For 8 in spools		
Small Running Gear/Cylinder Rack	#194776	For cylinders no larger than 7 in (178 mm), maximum weight 75 lb (34 kg)		
Running Gear/Cylinder Rack	#770187	For cylinders no larger than 7 in (178 mm), maximum weight 100 lb (45 kg)		
Protective Cover	#195186			
Replacement Drive Roll	#212379	Dual-groove, one smooth groove for .023/.025 in (0.6 mm), and one knurled groove for .030/.035 in (0.8/0.9 mm)		
Replacement Gun	#195343	H-9A MIG Gun, 8 ft (2.4 m) with liner for .023-.035 in (0.6-0.9 mm) diameter wire		
Contact Tips		See chart on pg 3		
Nozzle		See chart on pg 3		
Tip Adapter		See chart on pg 3		
Replacement Liner	#210970R	Liner for .023-.035 in (0.6-0.9 mm) wire		
Tools and Safety Items				
Date:			Total Quoted Price:	

HOBART

W E L D E R S

Litho in USA

DISTRIBUTED BY: