



# **5-Speed MINI DRILL PRESS**

## **OWNER'S MANUAL**



**⚠ WARNING:**

Read carefully and understand all INSTRUCTIONS before operating. Failure to follow the safety rules and other basic safety precautions may result in serious personal injury.

**Item # 155300**

Thank you very much for choosing a NORTHERN TOOL + EQUIPMENT CO., INC. Product!  
For future reference, please complete the owner's record below:

Model: \_\_\_\_\_ Purchase Date: \_\_\_\_\_

Save the receipt, warranty and these instructions. It is important that you read the entire manual to become familiar with this product before you begin using it.

This machine is designed for certain applications only. Northern Tool + Equipment cannot be responsible for issues arising from modification. We strongly recommend this machine is not modified and/or used for any application other than that for which it was designed. If you have any questions relative to a particular application, DO NOT use the machine until you have first contacted Northern Tool + Equipment to determine if it can or should be performed on the product.

For technical questions please call 1-800-222-5381.

## INTENDED USE

This mini drill press is designed for drilling in metal or wooden pieces.

## TECHNICAL SPECIFICATIONS

Description	Specifications
Motor:	1/3 HP
Volts:	120V
Speed:	620 - 3100 RPM
Chuck Size:	1/2"
Swing:	8"
Stroke:	2"
Drilling Capacity:	1/2"
Work table:	6 5/8" x 6 9/16"
Work base:	11 5/8" x 7 1/3"
Ship Weight:	42 lbs

## GENERAL SAFETY RULES

**⚠ WARNING! Read and understand all instructions.** Failure to follow all instructions listed below may result in electric shock, fire and/or serious injury.

**⚠ WARNING! The warnings, cautions, and instructions discussed in this instruction manual cannot cover all possible conditions or situations that could occur. It must be understood by the operator that common sense and caution are factors which cannot be built into this product, but must be supplied by the operator.**

### SAVE THESE INSTRUCTIONS

#### WORK AREA

- **Keep work area clean**, free of clutter and well lit. Cluttered and dark work areas can cause accidents.
- **Do not use your tool where there is a risk of causing a fire or an explosion;** e.g. in the presence of flammable liquids, gasses, or dust. Power tools create sparks, which may ignite the dust or fumes.
- **Keep children and bystanders** away while operating a power tool. Distractions can cause you to lose control, so visitors should remain at a safe distance from the work area.

- **Be aware of all power lines, electrical circuits**, water pipes and other mechanical hazards in your work area, particularly those hazards below the work surface hidden from the operator's view that may be unintentionally contacted and may cause personal harm or property damage.
- **Be alert of your surroundings.** Using power tools in confined work areas may put you dangerously close to cutting tools and rotating parts.

**ELECTRICAL SAFETY**

**⚠ WARNING!** Always check to ensure the power supply corresponds to the voltage on the rating plate.

- **Do not abuse the cord.** Never carry a portable tool by its power cord, or yank tool or extension cords from the receptacle. Keep power and extension cords away from heat, oil, sharp edges or moving parts. Replace damaged cords immediately. Damaged cords may cause a fire and increase the risk of electric shock.
- **Grounded tools** must be plugged into an outlet properly installed and grounded in accordance with all codes and ordinances. Never remove the grounding prong or modify the plug in any way. Do not use any adapter plugs. Check with a qualified electrician if you are in doubt as to whether the outlet is properly grounded.
- **Double insulated tools** are equipped with a polarized plug (one blade is wider than the other). This plug will fit in a polarized outlet only one way. If the plug does not fit fully in the outlet, reverse the plug. If it still doesn't fit, contact a qualified electrician to install a polarized outlet. Do not change the plug in any way.
- **Avoid body contact** with grounded surfaces such as pipes, radiators, ranges, and refrigerators. There is an increase risk of electric shock if your body is grounded.
- **When operating a power tool outside**, use an outdoor extension cord marked "W-A" or "W." These cords are rated for outdoor use and reduce the risk of electric shock.
- **Extension Cord Use:**
  - A. Use only 'Listed' extension cords. If used outdoors, they must be marked "For Outdoor Use." Those cords having 3-prong grounding type plugs and mating receptacles are to be used with grounded tools.
  - B. Replace damaged or worn cords immediately.
  - C. Check the name plate rating of your tool. Use of improper size or gauge of extension cord may cause unsafe or inefficient operation of your tool. Be sure your extension cord is rated to allow sufficient current flow to the motor. For the proper wire gauge for your tool, see chart.

**CHART FOR MINIMUM WIRE SIZE OF EXTENSION CORD:**

Nameplate AMPS	CORD LENGTH			
	25'	50'	100'	150'
0-6	18 AWG	16 AWG	16 AWG	14 AWG
6-10	18 AWG	16 AWG	14 AWG	12 AWG
10-12	16 AWG	16 AWG	14 AWG	12 AWG
12-16	14 AWG	12 AWG	(NOT RECOMMENDED)	

If in doubt, use larger cord. Be sure to check voltage requirements of the tool to your incoming power source.

- **Do not expose** power tools to rain or wet conditions. Water entering a power tool will increase the risk of electric shock.
- **Do not let your fingers** touch the terminals of plug when installing to or removing from the outlet.
- **Ground fault circuit interrupters.** If work area is not equipped with a permanently installed Ground Fault Circuit Interrupter outlet (GFCI), use a plug-in GFCI between power tool or extension cord and power receptacle.

**PERSONAL SAFETY**

- **Stay alert**, watch what you are doing and use common sense when operating a power tool. Do not use a power tool while you are tired or under the influence of drugs, alcohol or medication. A moment of inattention while operating power tools may result in serious personal injury.
- **Dress properly.** Do not wear loose clothing, dangling objects, or jewelry. Keep your hair, clothing and gloves away from moving parts. Loose clothes, jewelry or long hair can be caught in moving parts. Air vents often cover moving parts and should be avoided.
- **Use safety apparel and equipment.** Use safety goggles or safety glasses with side shields which comply with current national standards, or when needed, a face shield. Use as dust mask in dusty work conditions. This applies to all persons in the work area. Also use non-skid safety shoes, hardhat, gloves, dust collection systems, and hearing protection when appropriate.

- **Avoid accidental starting.** Do not carry the power tool with your finger on the switch. Ensure the switch is in the off position before plugging tool into power outlet. In the event of a power failure, while a tool is being used, turn the switch off to prevent surprise starting when power is restored.
- **Do not overreach.** Keep proper footing and balance at all times.
- **Remove adjusting keys or wrenches** before connecting to the power supply or turning on the tool. A wrench or key that is left attached to a rotating part of the tool may result in personal injury.
- **Never place your fingers in a position where they could contact the drill or other cutting tool** if the workpiece should unexpectedly shift or your hand should slip.
- **Whenever possible, position the WORKPIECE to contact the left side of the column if it is too short or the table is tilted,** clamp solidly to the table. Use table slots or clamping ledge around the outside edge of the table.
- **When using a drill press VISE, always fasten it to a table.**
- **Never climb on or allow others to climb on the drill press table;** it could break or pull the entire drill press down.
- **Turn the motor Switch OFF and put away the Switch Key when leaving the drill press.**
- **To avoid injury from thrown work or tool contact, do NOT perform layout, assembly, or setup work on the table while the cutting tool is rotating.**

#### TOOL USE AND CARE

- **Do not force the tool.** Tools do a better and safer job when used in the manner for which they are designed. Plan your work, and use the correct tool for the job.
- **Never use a tool** with a malfunctioning switch. Any power tool that cannot be controlled with the switch is dangerous and must be repaired by an authorized service representative before using.
- **Disconnect power** from tool and place the switch in the locked or off position before servicing, adjusting, installing accessories or attachments, or storing. Such preventive safety measures reduce the risk of starting the power tool accidentally.
- **Secure work** with clamps or a vise instead of your hand to hold work when practical. This safety precaution allows for proper tool operation using both hands.
- **Store idle tools.** When tools are not in use, store them in a dry, secure place out of the reach of children. Inspect tools for good working condition prior to storage and before re-use.
- **Use only accessories that are recommended** by the manufacturer for your model. Accessories that may be suitable for one tool may create a risk of injury when used on another tool.
- **Keep guards in place** and in working order.

For your own safety, do not try to use your drill press or plug it in until it is completely assembled and installed according to the instructions, read and understood this Instruction manual:

- Your drill press must be bolted securely to a workbench. In addition, if there is any tendency for your drill press to move during certain operations, bolt the workbench to the floor.
- This drill press is intended for use in dry conditions, indoor use only.
- Always keep hands out of the path of a drill bit. Avoid awkward hand positions where a sudden slip could cause your hand to move into the drill bit.
- Do not install or use any drill bit that exceeds 175 mm (7") in length or extends 150 mm (6") below the chuck jaws. They can suddenly bend outward or break.
- Do not use wire wheels, router bits, shaper cutters, circle (fly) cutters, or rotary planers on this drill press.
- When cutting a large piece of material make sure it is fully supported at the table height.
- Do not perform any operation freehand. Always hold the workpiece firmly against the table so it will not rock or twist. Use clamps or a vice for unstable workpieces.
- Make sure there are no nails or foreign objects in the part of the workpiece to be drilled.
- Do not touch the bit or chips. Drill bits and cuttings are hot immediately after drilling.
- Never reach around or under the working head, or grab the chuck key to stop the drill press.
- Make sure the drill press speed is appropriate for both the type of material and bit size you are using.

- Clamp workpiece or brace against the left side of the column to prevent rotation. If it is too short or the table is tilted, clamp solidly to the table and use the fence provided.
- If the workpiece overhangs the table such that it will fall or tip if not held, clamp it to the table. Provide auxiliary support.
- Make sure all clamps and locks are firmly tightened before drilling.
- Securely lock the head and table support to the column, and the table to the table support before operating the drill press.
- Never turn your drill press on before clearing the table of all objects. (tools, scraps of wood, etc.)
- Before starting the operation, jog the motor switch to make sure the drill bit does not wobble or vibrate.
- Let the spindle reach full speed before starting to drill. If your drill press makes an unfamiliar noise or if it vibrates excessively, stop immediately, turn the drill press off and unplug. Do not restart until the problem is corrected.
- Do not perform layout assembly or set up work on the table while the drill press is in operation.
- Make sure the spindle has come to a complete stop before touching the workpiece.
- To avoid injury from accidental starting, always turn the switch "OFF" and unplug the drill press before installing or removing any accessory or attachment or making any adjustment.
- Keep guards in place and in working order.
- Use only self-ejecting type chuck key as provided with the drill press.
- Do not try to drill material too small to be securely held.
- Use the drill press in a well-lit area and on a level surface clean and smooth enough to reduce the risk of trips, slips, or falls. Use it where neither the operator nor a casual observer is forced to stand in line with a potential kickback.
- Never leave tool running unattended.

**⚠ WARNING!** For your own safety, do not attempt to operate your drill press until it is completely assembled and installed according to the instructions and until you have read and understand the following:

1. **General Safety Instructions for Power Tools**
2. **Getting to Know Your Drill Press**
3. **Basic Drill Press Operation**
4. **Adjustments**
5. **Maintenance**

## UNPACKING

On receipt, carefully unpack the components ensuring that no damage was suffered in transit, and that all following parts are accounted for.

1. Table Support
2. Support Lock Handle
3. Column
4. Base
5. Support column
6. Screw Hex HD M8 x 20
7. Table Bevel Lock Screw
8. Table
9. Head Arm

Check the parts against the above list and refer to the diagrams. Should there be any deficiencies or damage, you should contact Northern Tool + Equipment.

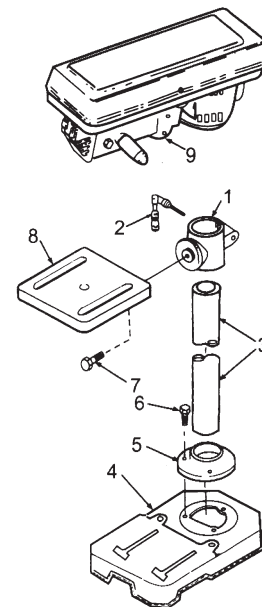

## GETTING TO KNOW YOUR DRILL PRESS

1. Pulley-Guard
2. Belt Tension Lock Handle
3. Head Lock Set Screws
4. Support-Table
5. Column-support
6. Support-Lock
7. Base
8. Spring-Cap
9. Depth-Scale Indicator
10. Depth-Scale
11. Column
12. Bevel Scale
13. Table Lock Set Screw
14. Table
15. Feed Handles
16. Chuck
17. Feed Stoop Rod
18. Stop Nuts
19. Switch
20. Stop-Motor  
Spring Motor Stop

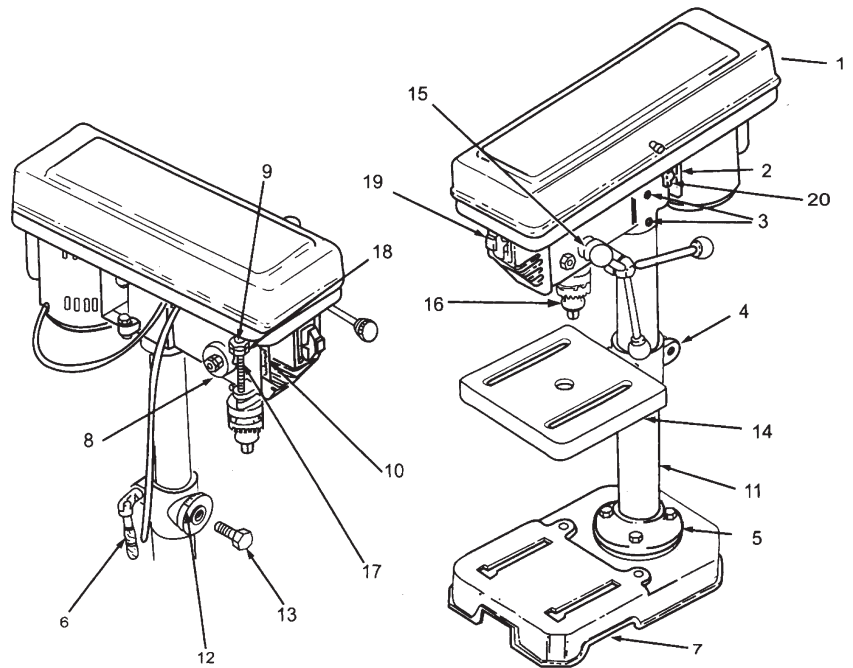

## ASSEMBLY

1. Install (3) M8 x 20 bolts in each hole through Column Support and base and tighten with wrench.
2. Slide table/support into column.
3. Install support lock handle from left side into table support and tighten by hand.
4. Lift head above column and slide it onto the column as possible. Align head with table and base. Using a 4mm Hex "L" wrench, tighten the head lock set screws on the head.
5. Screw the feed handles into the threaded holes in the hub and tighten.
6. Clean out the tapered hole in the chuck. Clean the spindle nose with a clean cloth. Push the chuck up on the spindle nose as far as possible. Lightly tap the nose of the chuck with a piece of wood to ensure proper fitting of the chuck on the spindle.
7. Install M5 x 12 pan HD screw in hole located in guard and attach knob, turning until tighten.
8. Choose speed for drilling operation, and install belt to correct position for desired speed. Loosen belt tension lock handle and turn the motor counterclockwisely to apply tension to the belt. Tighten belt tension lock handle.

## OPERATION

1. Before using this machine, the operator should carefully read over this operation manual to acquaint himself with the construction, controls and driving system of the machine.
2. All of the Ball Bearing are packed with grease at the factory. They require no further lubrication. Periodically lubricate the grooves in the spindle and the rack (teeth of the quill).
3. Install drill into chuck far enough to obtain maximum gripping of the chuck jaws. Make sure that the drill is centered in the chuck. Tighten the drill sufficiently, so that it does not slip while drilling. Turn the chuck key clockwise to tighten, counter-clockwise to loosen the drill bit.
4. The drilling depth may be controlled by pointer and depth scale or by the two stop nuts, on the feed stop rod.

5. To position the table, loosen support lock handle, move the table to the desired position and retighten support lock.  
To tilt table, loosen the bevel lock, tilt the table to desired position on the bevel scale and retighten bevel lock.
6. After drilling a hole, release the feed handle to have the spindle sleeve return to its original position.
7. In case of any trouble or abnormal noise arising during operation, stop the motor at once and find out the cause.
8. After operation, remove chips and dirt on the machine and cover all the unpainted surfaces with oil to prevent them from rusting. Turn off the power supply for safety.

## MAINTENANCE

 **WARNING!** For your own safety, turn switch “off” and remove plug from power source outlet before maintaining or lubricating your drill press.

 **WARNING!** To avoid shock or fire hazard, if the power cord is worn or cut, or damaged in any way, have it replaced.

 **WARNING!** Make sure this tool is disconnected from its power source before attempting any maintenance, cleaning, or inspection.

- **Maintain your tools.** It is recommended that the general condition of any tool be examined before it is used. Keep your tools in good repair by adopting a program of conscientious repair and maintenance in accordance with the recommended procedures found in this manual. If any abnormal vibrations or noise occurs, turn the tool off immediately and have the problem corrected before further use. Have necessary repairs made by qualified service personnel.
- **Keep cutting tools sharp and clean.** Properly maintained cutting tools with sharp cutting edges are less likely to bind and are easier to control. Keep handles dry, clean, and free from oil and grease.
- **Cleaning.** Use only soap and a damp cloth to clean your tools. Many household cleaners are harmful to plastics and other insulation. Never let liquid get inside a tool.

## WARRANTY

**One-Year Limited Warranty**

**For warranty questions, call 1-800-222-5381**

## DIAGRAM & PARTS LIST

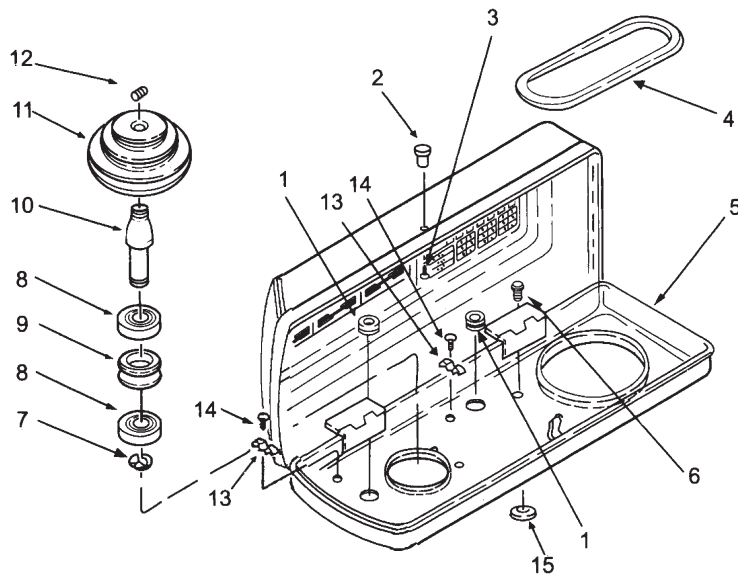
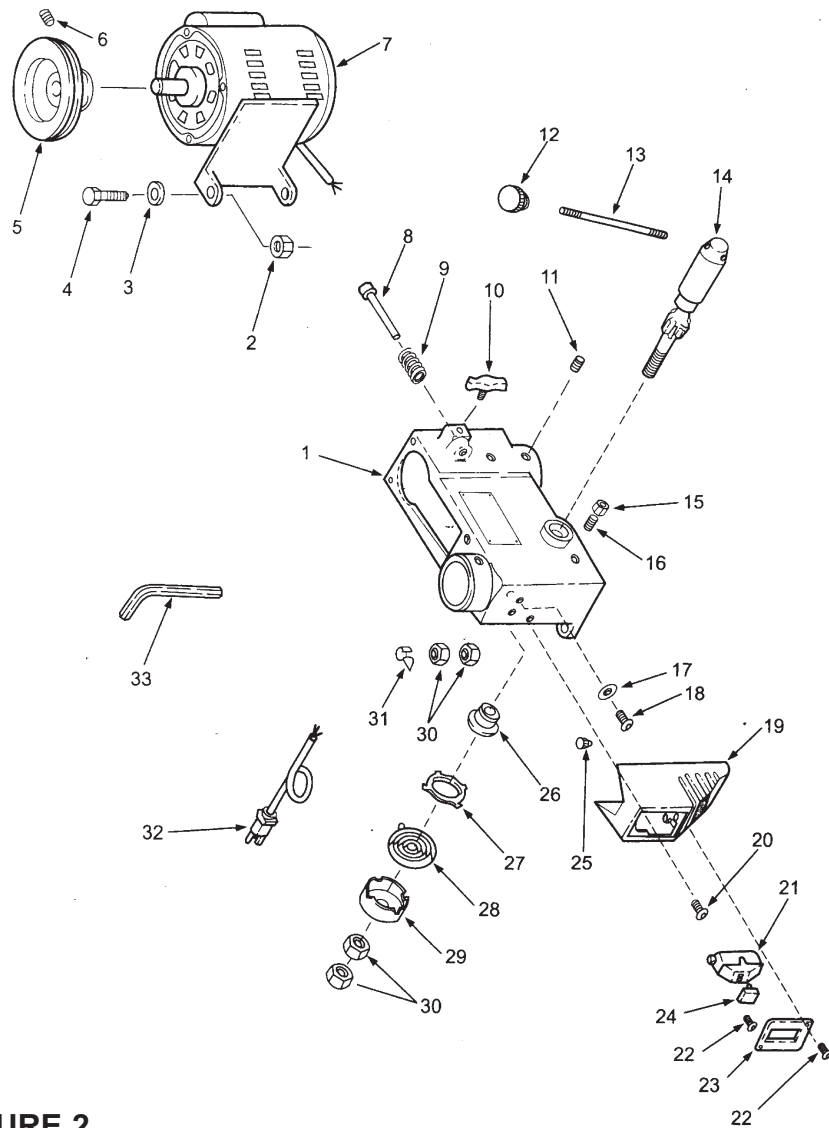

FIGURE 1

Key No.	Description	Key No.	Description
1	Bushing-Rubber	8	* Bearing-Ball 17mm
2	Knob	9	Spacer
3	Screw- Pan Hd. M5×0.8-12	10	Insert-Pulley
4	Belt-"V"5/16×26	11	Pulley-Spindle
5	Guard W/Labels	12	Screw M6×1-12
6	Screw- Washer Hd. M6×1.0-12	13	Clamp Cord
7	Ring Retaining 17	14	Screw Pan Hd. M5×0.8-16
		15	Washer, Foam



**FIGURE 2**

Key No.	Description	Key No.	Description
1	Head w/Roll Pin & Trim	19	Box-Switch w/Depth Scale
2	Nut-Lock M8×1.25-8	20	Screw-Pan Cr. M5×0.5-12
3	* Washer-5/16×11/16×1/16	21	Switch- Locking
4	* Screw-Hex M8×1.25-25	22	Screw-Self Tapping Pan Hd. ST4.2×9.5
5	Pulley-Motor	23	Cover- Switch Plate
6	Screw-Hex Soc. Set M6×1.0-10	24	* Key-Switch
7	Motor	25	* Connector- Wire
8	Stop-Motor	26	Seat-Spring
9	Spring-Motor Stop	27	Retainer-Spring
10	Knob-Motor Adjusting	28	Spring-Tension
11	Screw- Hex Soc. Set M8×1.25-8	29	Cap-Spring
12	Knob	30	* Nut-Hex 3/8-24
13	Rod	31	* Nut-Hex M10×1.5
14	Shaft-Pinion	32	Pointer
15	* Nut-Hex M8×1.25	33	Cord-Power
16	Screw-Flt. Slt. Set M8×1.25	34	Wrench Hex "L"4mm
17	* Lock washer-Ext. 5mm		Owners Manual
18	Screw- Pan Hd. M5×0.8-8		(Not Illustrated)

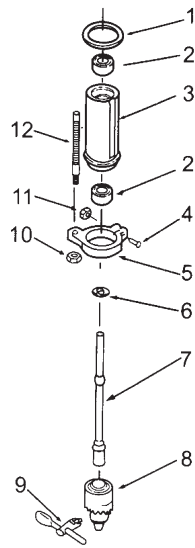

**FIGURE 3 QUILL ASSEMBLY**

Key No.	Description
1	Gasket-Quill
2	* Beating-Ball 12mm
3	Tube-Quill
4	Screw-pan M5 x 0.8-20
5	Collar-Stop
6	Ring-Retaining
7	Shaft-Spindle
8	Chuck
9	Key- Chuck
10	* Nut-Hex M6 x 1.0
11	* Nut-Hex M5 x 0.8
12	Rod-Stop

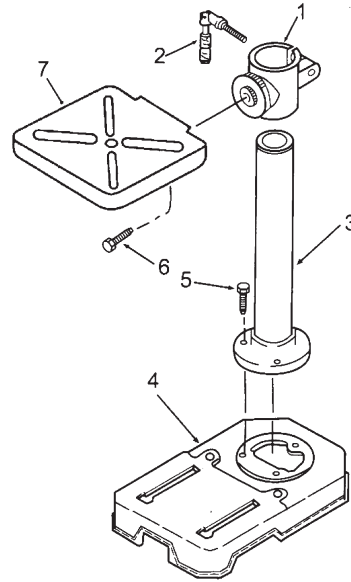

**FIGURE 4**

Key No.	Description
1	Support-Table w/Scale
2	Support-Lock Handle
3	Tube/Support
4	Base
5	* Screw-Hwx Hd. M8 x 1.25-20
6	Screw-Hex Hd. M12 x 20
7	Table

 **WARNING**

Some dust created by power sanding, sawing, grinding, drilling, and other construction activities contains chemicals known to the State of California to cause cancer, birth defects or other reproductive harm. Some examples of these chemicals are:

- lead from lead-based paints,
- crystalline silica from bricks and cement and other masonry products, and
- arsenic and chromium from chemically-treated lumber.

Your risk from these exposures varies, depending on how often you do this type of work. To reduce your exposure to these chemicals: work in a well ventilated area, and work with approved safety equipment, such as those dust masks that are specially designed to filter out microscopic particles.



Northern Tool + Equipment Co.,  
2800 Southcross Drive West  
P.O. Box 1499 Burnsville, MN 55337-0499  
Made in China