



## 2-SHELF WORKBENCH W/DRAWER

### OWNER'S MANUAL



**WARNING:** Read carefully and understand all **INSTRUCTIONS** before operating. Failure to follow the safety rules and other basic safety precautions may result in serious personal injury.

Item # 150509

Thank you very much for choosing a NORTHERN TOOL + EQUIPMENT CO., INC. Product! For future reference, please complete the owner's record below:

Model: \_\_\_\_\_ Purchase Date: \_\_\_\_\_

Save the receipt, warranty and these instructions. It is important that you read the entire manual to become familiar with this product before you begin using it.

This machine is designed for certain applications only. Northern Tool + Equipment cannot be responsible for issues arising from modification. We strongly recommend this machine is not modified and/or used for any application other than that for which it was designed. If you have any questions relative to a particular application, DO NOT use the machine until you have first contacted Northern Tool + Equipment to determine if it can or should be performed on the product.

For technical questions please call **1-800-222-5381**.

## SAFETY INSTRUCTIONS

These units should be placed on a level surface. Failure to do so can result in poor product performance or create a possible safety hazard. This unit should be securely anchored to a wall or floor with suitable fasteners, which are included. Do not use this unit for anything other than the manufactures intended purpose. **DO NOT STAND ON ANY PART OF THE UNIT, OR USE IT AS A LADDER.** Evenly distribute the weight on each level and always keep the heavier loads on the bottom. Use care when working with metal parts. Do not exceed the maximum capacity of 300 lbs. for each shelf. Keep children away; do not allow them to play with or crawl/climb on unit.

## GENERAL INSTRUCTIONS

Assembly is done with the rivets of the beams and braces fitting into the slots of the post. A rubber mallet may be used on the beams and braces to seat the rivets properly. A hammer can also be used providing one uses a cloth or a block of wood between the hammer head and the parts to prevent damage. Tap gently and be sure the rivets are straight and fully engaged. Periodically inspect the general condition of the rack for loose frame connections, undistributed loads, shelving deformations and any other conditions that may affect the rack's stability and performance.

## ASSEMBLY INSTRUCTION

Required Tools (Rubber Mallet, Philips Screwdriver, Wrench)

### **Step 1: (Note: Post are directional. The slot must point down.)**

Take one (1) 38 3/8" bottom back post (top end has a half slot hole), and one (1) 36" top right back post (top has slot holes, bottom has rivets) and create a coupled back post. Take one (1) 17 1/8" brace (**shelf ledge up**), and one (1) 35" front post and attach the rivets of the brace to the top two (2) holes of the front post. Take the coupled back post and attach the opposite rivets to the holes so **the brace is level**. Tap brace down to seat. Attach the bottom 17 1/8" brace to the front post **skipping one (1) hole from the bottom**, and the opposite end level to the coupled back post. Tap brace down to seat. Take one (1) drawer mount and insert the rivets two

(2) slot hole below the 17 1/8" top brace on both ends, and tap to seat. Repeat steps for the opposite end assembly.

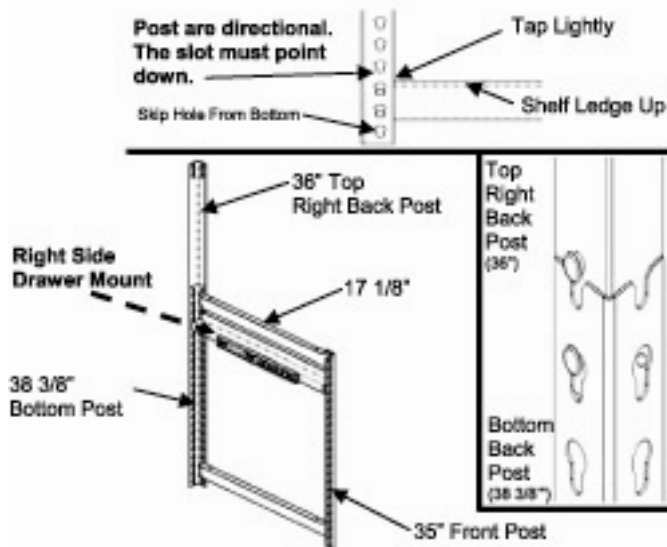

## STEP 2

Take Four (4) 35 1/8" beams with **the shelf ledge facing up**. And attach two (2) even with the end assembly's bottom braces, and two (2) even with the braces at the top. Install one (1) back 35" **Flat** beam with the **bend facing down**, to the top holes of the top back posts. Take the two (2) support extensions, and install one (1) **35"**beam with the **bend facing down**, to the front holes of the top support extensions to create the top shelf assembly. Take the support extension's rivets of the assembly, and install the top shelf assembly even with the rivets of the 35" back **Flat** beam of the unit.

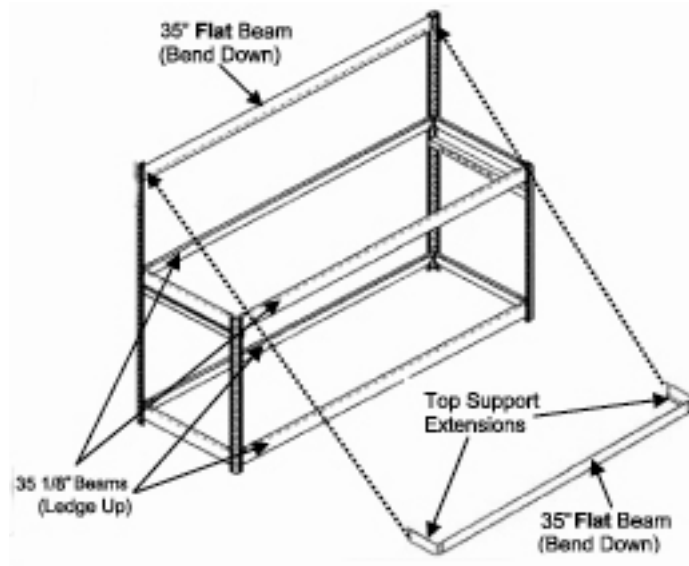

## STEP 3

Place the two (2) halves of the peg board to the inside of the back post of the work bench. Align the holes of the peg board to holes on the back post, Fasten using the nuts and bolts provided. Take two (2) drawer slides, one (1) silver and one (1) black 31" Flat drawer braces. With the **bend facing down**, insert the rivets of the **black** brace into the slot and half slot holes located on the **back** end of the drawer slides. Insert the laminated shelf, and install the **silver** front

drawer brace to the front of the drawer slides. Install the drawer assembly to the drawer mounts slides of the unit.

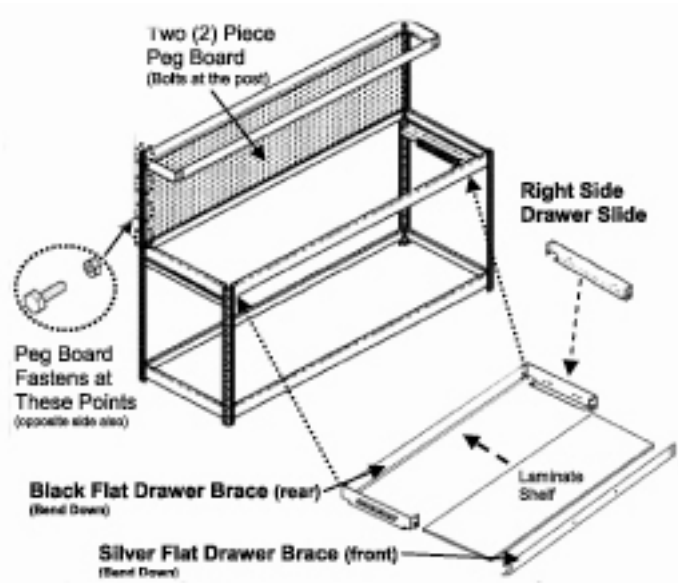

#### STEP 4

Install the handle to the front drawer brace, and add the laminate shelves to the top shelf, bottom shelf, and work surface to finalize the assembly of the workbench. Optional anchor hardware is supplied with this unit so the unit can be fastened to a wall if necessary. See instructions for installing anchor hardware.

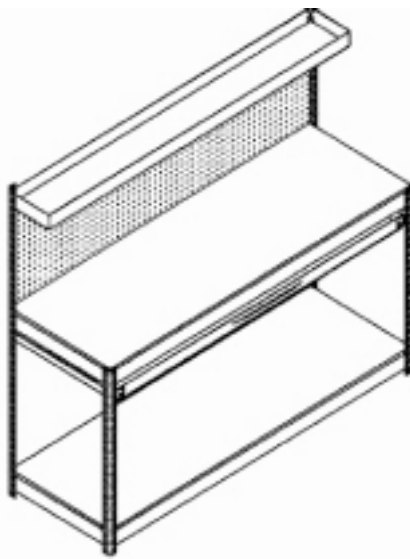

### Anchor Hardware Instructions

**Wood Stud Installation-** Drill an applicable small pilot hole even with the hole of the post into the wood stud. Use a drill or screwdriver, and fasten the screw and washer through the hole of the post, and into the wood stud.

**Wall Board Installation-** Drill an applicable hole even with the hole of the post into the wall board. Insert the wall anchor into the wall board. Use a drill or screw driver, and fasten the screw and washer through the hole of the post, and into the wall anchor.

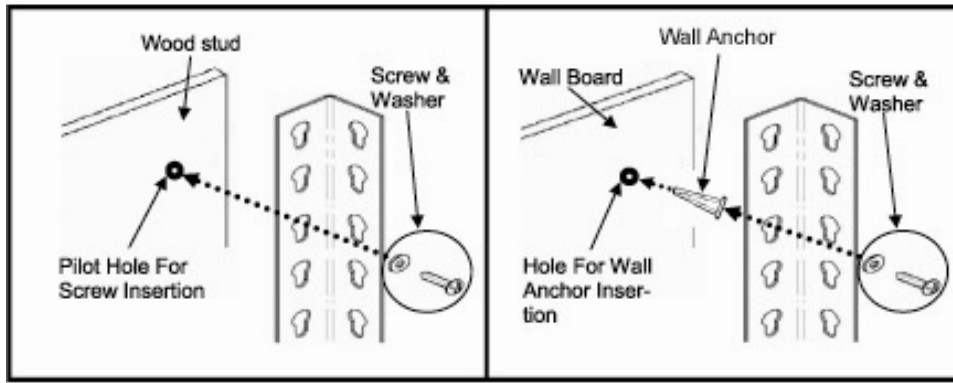

## Parts List

Description	Qty.	Part Number	Part Size
Top Back Post Right	1	RUPTSPR3702S	36"
Top Back Post Left	1	RUPTSPL3702S	36"
Bottom Back Post	2	RUPTSP3802S	36 3/8"
Front Post	2	RUPT3502S	35"
Braces	4	RUBE1702	17 1/8"
Beams	4	RUBE3502	35 1/8"
Left Top Support Extension	1	RWTE0802L	9"
Right Top Support Extension	1	RWTE0802R	9"
Top Shelf Flat Beam	2	RMBE3502	35"
Left Drawer Mount	1	SVRWDM1705L	N/A
Right Drawer Mount	1	SVRWDM1705R	N/A
Left Drawer Slide	1	SVRWDS1403L	N/A
Right Drawer Slide	1	SVRWS1403R	N/A
Front Drawer Shelf Brace	1	SVRWDB3102F	31"
Back Drawer Shelf Brace	1	SVRWDB3102B	31"
Steel Peg Board	2	SPGBE1536	16 3/8" × 35 3/4"
Laminate Sheelves	2	RPB21836LM	17 1/2" × 35 1/2"
Laminate Drawer Shelf	1	RPB31011LM	11 3/4" × 31"
Laminate Top Shelf	1	RPB2369LM	9" × 35 1/2"
Nuts, Bolts	8	NB8	N/A
Handle	1	HDL1000	N/A
Wall Anchor, Screw, Washer	2	N/A	N/A
Post Connector	1	N/A	N/A

For replacement parts and technical questions, please call **1-800-222-5381**.



Northern Tool + Equipment Co., Inc.  
 2800 Southcross Drive West  
 P.O. Box 1499 Burnsville, MN 55337-0499  
 Made in China