



3.5-GALLON PARTS WASHER

OWNER'S MANUAL



 **WARNING:** Read carefully and understand all **INSTRUCTIONS** before operating. Failure to follow the safety rules and other basic safety precautions may result in serious personal injury.

Item #141222

Thank you very much for choosing a NORTHERN TOOL + EQUIPMENT CO., INC. Product! For future reference, please complete the owner's record below:

Model: _____ Purchase Date: _____

Save the receipt, warranty and these instructions. It is important that you read the entire manual to become familiar with this product before you begin using it.

This machine is designed for certain applications only. Northern Tool + Equipment cannot be responsible for issues arising from modification. We strongly recommend this machine is not modified and/or used for any application other than that for which it was designed. If you have any questions relative to a particular application, DO NOT use the machine until you have first contacted Northern Tool + Equipment to determine if it can or should be performed on the product.

For technical questions please call **1-800-222-5381**.

INTENDED USE

Suitable for rapid cleaning of small mechanical parts, motor parts, etc

TECHNICAL SPECIFICATIONS & PACKING LIST

Item	Description
Tub Size	18in. x 14in. x 9in. (45.72x35.56x22.86cm)
Assembled Dims	17in. x 13.5in. x 9in. (43.18x34.29x22.86cm)
Electrical Requirements	120V, 60HZ

GENERAL SAFETY RULES



WARNING: Read and understand all instructions. Failure to follow all instructions listed below may result in electric shock, fire and/or serious injury.



WARNING: The warnings, cautions, and instructions discussed in this instruction manual cannot cover all possible conditions or situations that could occur. It must be understood by the operator that common sense and caution are factors which cannot be built into this product, but must be supplied by the operator.

SAVE THESE INSTRUCTIONS

WORK AREA

- **Keep work area clean**, free of clutter and well lit. Cluttered and dark work areas can cause accidents.
- **Do not use your parts washer where there is a risk of causing a fire or an explosion;** e.g. in the presence of flammable liquids, gasses, or dust.
- **Keep children and bystanders** away while operating a parts washer. Distractions can cause you to lose control, so visitors should remain at a safe distance from the work area.

- **Be aware of all power lines, electrical circuits,** water pipes and other mechanical hazards in your work area, particularly those hazards below the work surface hidden from the operator's view that may be unintentionally contacted and may cause personal harm or property damage.
- **Be alert of your surroundings.** Using parts washers in confined work areas may put you dangerously close to cutting tools and rotating parts.

ELECTRICAL SAFETY



WARNING: Always check to ensure the power supply corresponds to the voltage on the rating plate.

- **Do not abuse the cord.** Never yank tool or extension cords from the receptacle. Keep power and extension cords away from heat, oil, sharp edges or moving parts. Replace damaged cords immediately. Damaged cords may cause a fire and increase the risk of electric shock.
- **Grounded tools** must be plugged into an outlet properly installed and grounded in accordance with all codes and ordinances. Never remove the grounding prong or modify the plug in any way. Do not use any adapter plugs. Check with a qualified electrician if you are in doubt as to whether the outlet is properly grounded.
- **Double insulated tools** are equipped with a polarized plug (one blade is wider than the other). This plug will fit in a polarized outlet only one way. If the plug does not fit fully in the outlet, reverse the plug. If it still doesn't fit, contact a qualified electrician to install a polarized outlet. Do not change the plug in any way.
- **Avoid body contact** with grounded surfaces such as pipes, radiators, ranges, and refrigerators. There is an increase risk of electric shock if your body is grounded.
- **Do not let your fingers** touch the terminals of plug when installing to or removing from the outlet.
- **Ground fault circuit interrupters.** If work area is not equipped with a permanently installed Ground Fault Circuit Interrupter outlet (GFCI), use a plug-in GFCI between power tool or extension cord and power receptacle.

PERSONAL SAFETY

- **Stay alert,** watch what you are doing and use common sense when operating a parts washer. Do not use a parts washer while you are tired or under the influence of drugs, alcohol or medication. A moment of inattention while operating a parts washer may result in serious personal injury.
- **Dress properly.** Do not wear loose clothing, dangling objects, or jewelry. Keep your hair, clothing and gloves away from moving parts. Loose clothes, jewelry or long hair can be caught in moving parts. Air vents often cover moving parts and should be avoided.
- **Use safety apparel and equipment.** Use safety goggles or safety glasses with side shields which comply with current national standards, or when needed, a face shield. Use as dust mask in dusty work conditions. This applies to all persons in the work area. Also use non-skid safety shoes, hardhat, gloves, dust collection systems, and hearing protection when appropriate.
- **Avoid accidental starting.** Ensure the switch is in the off position before plugging tool into power outlet. In the event of a power failure, while a parts washer is being used, turn the switch off to prevent surprise starting when power is restored.
- **Do not overreach.** Keep proper footing and balance at all times.

TOOL USE AND CARE

- **Never use a parts washer** with a malfunctioning switch. Any parts washer that cannot be controlled with the switch is dangerous and must be repaired by an authorized service representative before using.
- **Disconnect power** from parts washer and place the switch in the locked or off position before servicing, adjusting, installing accessories or attachments, or storing. Such preventive safety measures reduce the risk of starting the parts washer accidentally.
- **Store idle parts washers.** When parts washer is not in use, store it in a dry, secure place out of the reach of children. Inspect parts washer for good working condition prior to storage and before re-use.
- **Use only accessories that are recommended** by the manufacturer for your model. Accessories that may be suitable for one parts washer may create a risk of injury when used on another parts washer.
- **Keep guards in place** and in working order.
- **Never leave parts washer** running unattended.

POWER SOURCE CONNECTION

POWER REQUIREMENTS

This product is designed to operate on a properly grounded 120 Volt, 60Hz, single-phase alternating current (AC) power source fused with a 20 Amp time-delayed fuse or circuit breaker. It is recommended that a qualified electrician verify the **ACTUAL VOLTAGE** at the receptacle into which the product will be plugged and confirm that the receptacle is properly fused and grounded.

DO NOT OPERATE THIS PRODUCT if the **ACTUAL** power source voltage is less than 105 Volts AC or greater than 132 Volts AC. Contact a qualified electrician if this problem exists. Improper performance and/or damage to the product will result if operated on inadequate or excessive power.

CONNECT TO POWER SOURCE

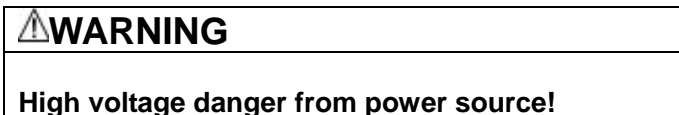

Consult a qualified electrician for proper installation of receptacle at the power source.

This product must be grounded while in use to protect the operator from electrical shock. If you are not sure if your outlet is properly grounded, have it checked by a qualified electrician. Do not cut off the grounding prong or alter the plug in any way and do not use any adapters between the product's power cord and the power source receptacle. Make sure the POWER switch is OFF then connect the power cord to a properly grounded 120V AC, 60Hz, single phase, 20 Amp power source.

EXTENSION CORDS

For optimum performance, an extension cord should not be used unless absolutely necessary. If necessary, care must be taken in selecting an extension cord appropriate for use with your specific product.

Select a properly grounded extension cord that will mate directly with the power source receptacle and the power cord without the use of adapters. Make certain that the extension is properly wired and in good electrical condition.

Extension cords must be a #12-gauge cord at the smallest. Do not use an extension cord over 25 ft. in length.

NOTICE:

The pump of your parts washer may be damaged if you use solvents other than those listed.

OPERATION

Always wear protective clothing, gloves and goggles when using your Parts Washer.

1. Open the Parts Washer Lid and place parts to be washed on the parts shelf.
2. Position the Flexible Nozzle so that it is directly above your parts.
3. Turn the Power Switch to the ON position.
4. Clean parts as needed.
5. Turn Power Switch to the OFF position.
6. Keep work area tidy and mop up any accidental spills of degreaser.

NOTE:

1. Place parts washer on firm, flat, level surface in a well-ventilated area and away from any open flames.
2. Fill only with a non-flammable water-based degreaser or cleaning agent, such as Simple Green, to just below the level of the parts shelf (approximately 3 gallons).
3. Follow the degreaser manufacturer's instructions carefully.
4. Do not fill with flammable solvents such as kerosene, gasoline, etc.

**WARNING**

Clean off any accidental splashes of degreaser on skin immediately, following the degreaser manufacturer's instructions carefully. Seek medical attention if necessary.

NOTE: Switch off pump, close the lid and disconnect from the electrical supply when not in use.

MAINTENANCE



WARNING: Make sure this parts washer is disconnected from its power source before attempting any maintenance, cleaning, or inspection.

- **Maintain your parts washer.** It is recommended that the general condition of any parts washer be examined before it is used. Keep your parts washer in good repair by adopting a program of conscientious repair and maintenance in accordance with the recommended procedures found in this manual. If any abnormal vibrations or noise occurs, turn the tool off immediately and have the problem corrected before further use. Have necessary repairs made by qualified service personnel.
- **Cleaning.** Use only soap and a damp cloth to clean your parts washer. Many household cleaners are harmful to plastics and other insulation. Never let liquid get inside a motor.
- The lid incorporates a fusible link to close the lid in the event of a fire. This link is non-resetting and must be replaced once it has been triggered.
- Make sure the holes in the removable parts shelf are free of debris.

- Do not allow the level of liquid in the parts washer to fall below the pump inlet, as damage to the pump can result.
- Change degreaser as needed.

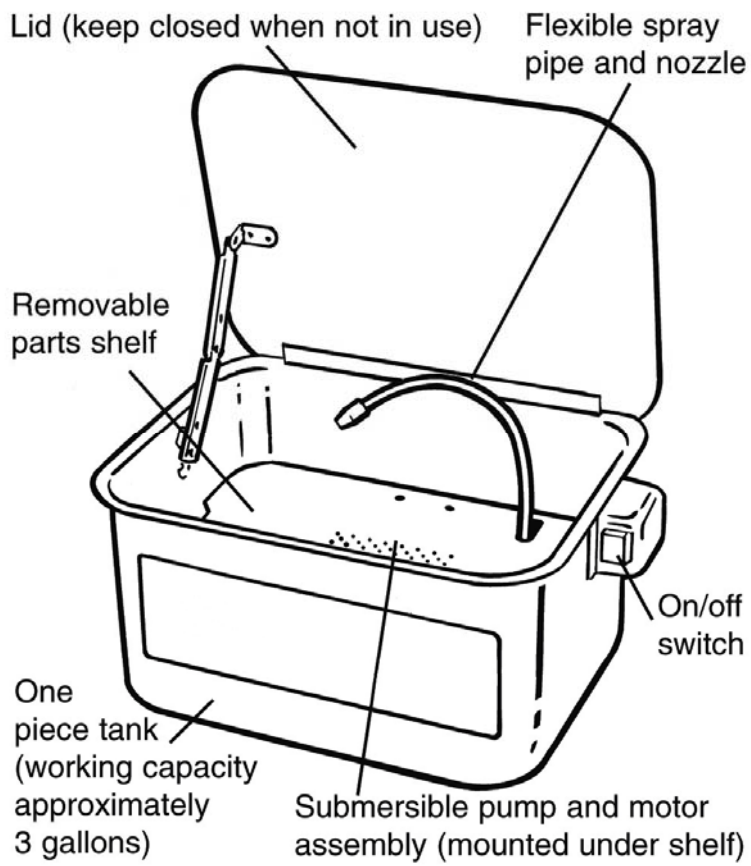
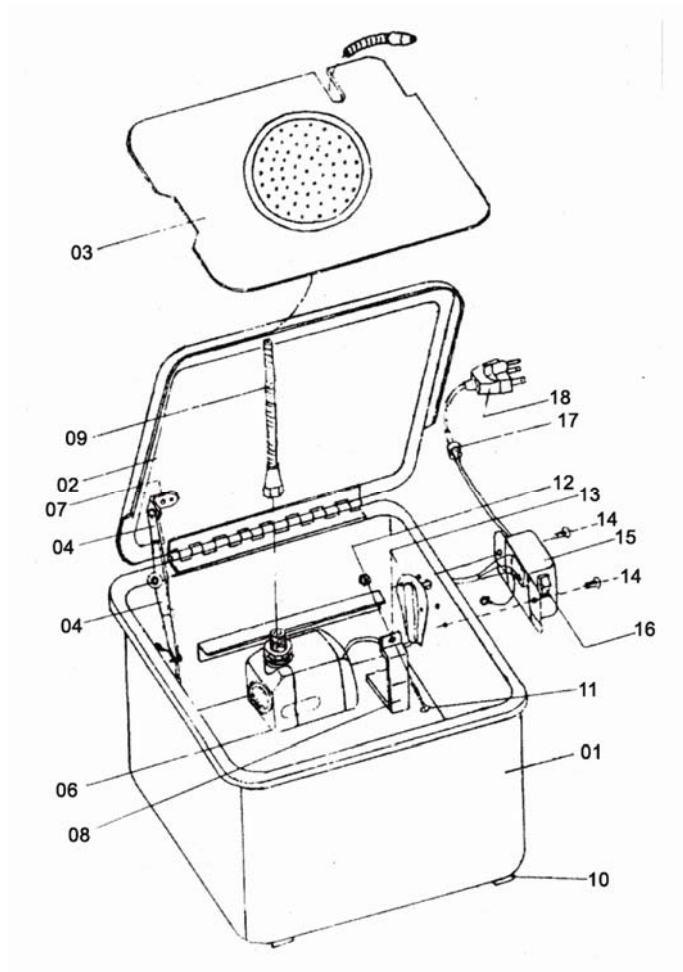

DIAGRAM & PARTS LIST



Part#	Description	Qty.	Part#	Description	Qty.
01	Tank	1	10	Plastic Foot	4
02	Lid	1	11	M5x30 Screw	1
03	Heavy-Duty Removable Work Shelf	1	12	M5 Nut	1
04	Fusible Linked Lid Arm	2	13	Cover	1
06	Pump	1	14	M4x12 Screw	3
07	Rivet	5	15	Switch Box	1
08	Pump Holder	1	16	Switch	1
09	Flexible Metal Spigot	1	17	Strain Relief	1
			18	Power cord	1

For replacement parts and technical questions, please call **1-800-222-5381**.

WARRANTY

One-Year Limited Warranty



Northern Tool + Equipment Co.,
2800 Southcross Drive West
P.O. Box 1499 Burnsville, MN 55337-0499
Made in China