

# INSTALL INSTRUCTIONS OPERATORS MANUAL PE 3500 12 VOLT DC ATV WINCH PERMANENT MAGNET MOTOR

Part #76-50112



2121 Blount Road \* Pompano Beach, FL 33069 \* USA

**Toll Free:** 1-800-886-8647

**International & Local:** 1-954-782-0604

**Fax:** 1-954-782-0770

**Email:** [info@milemarker.com](mailto:info@milemarker.com)

**Website:** <http://www.milemarker.com>

# Model PE 3500

## P/N 76-50112

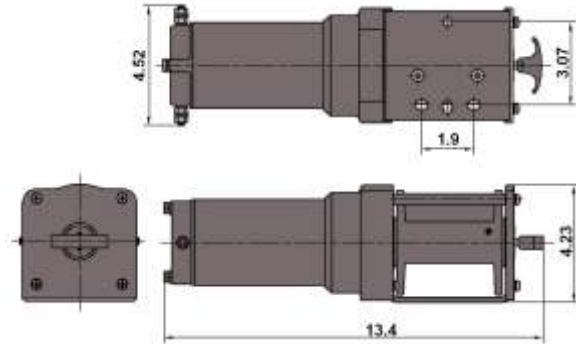

### Features:

- Automatic Load Holding brake
- Planetary gear system for fast line speed
- Free spooling
- Power IN and Power OUT
- 2Hp (1.5kw) heavy duty electric permanent magnetic motor
- Low electric current

### Specifications:

Rated Line Pull	3500 lbs. (1588kg) Single Line
Gear Reduction Ratio	216:1
Motor (Permanent Magnet)	2 Hp(1.5kw), 12 Volt DC
Drum Size (Diameter x Length)	1.5" (38mm) X 3.23" (82mm)
Cable supplied (min. Break force 5600lbs.)	7/32" (5.45mm) X 50 ft. (15.2m) galvanized aircraft cable
Overall Dimension (Length x Width x Height)	13.4" x 4.23" x 4.3" (340mmx107.5mmx109mm)
Net Weight	22.05 lb (10kg)
Mounting bolt pattern	1.9" (48mm) x 3.07" (77.98mm)

### Line Pull & Cable Capacity by Layer

Line Pull		Line Speed		Motor Current	Cable Layer	Rated Line Pull		Cable Capacity	
lbs	kg	fpm	mpm	12 V Amp		lbs	kg	ft	meters
0	0	1.5	4.6	10	1	3500	1589	6.5	2
1000	454	9.2	2.8	40	2	2800	1270	14.7	4.5
2000	908	7.5	2.3	80	3	2336	1060	25	7.5
3000	1362	5	1.5	120	4	2000	908	36	11
3500	1589	4	1.2	140	5	1750	795	45	13.7



# Safety Warnings & Precautions



Do not operate winch under influence of drugs or alcohol.

Read manual before using any winch.

Always use heavy gloves when handling wire rope.

Never hook the cable back upon itself. The cable can break under tension and cause injury and damage.

Stay clear of wire rope and keep others away when in operation or with load on wire.

Inspect winch and wire rope before each use. Do not use winch if wire rope or winch shows wear or damage.

Replace any parts as needed before using the winch.

Do not exceed the winch capacity.

Do not place hands near the fairlead when winch is in operation. Always use the protective hand strap.

Do not use the winch as a hoist or to move people.

Do not use winch to secure a load or tow vehicles.

Do not submerge winch in water.

Avoid injury and property damage, be safe and think first before operating winch. Use common sense.

Electric winch is for intermittent use only, 12 V DC.

Look to see where the drill bit will come through before drilling holes for installation. Never drill into the gas tank or electrical wiring.

Place towel or sandbag over wire while winch is in use.

# Installation Instructions

When installing a winch, your installation may vary from the manual diagrams and instructions included here due to vehicle and mounting options in the structure.

Always disconnect the battery from the vehicle to remove the electric hazard.

## **CAUTION**

**If you choose not to use an ATV mounting kit you may be required to drill holes in a structural support on the ATV. Be sure the location will be strong enough to support the rated pulling force of the winch. Do not drill into wiring or gas tank! If the mounting bolts needed are different length than supplied, use a bolt of equal or better quality to that supplied by the manufacture. Torque the kit's 5/16" Grade 5 mounting bolts to 12 ft lbs.(1.7kg-m)**

## **Step #1**

Install the mounting kit or prepare a flat and secure location on the ATV for the winch. The winch mount kit has it's own instructions for the intended ATV.

## **Step #2**

Position the winch over the mount and check for operation of the clutch lever to frame clearance. Check for tire to winch clearance. If ok, continue on to the next step.

## **Step #3**

Secure the winch to the mounting bracket or surface chosen with the correct hardware.

**NOTE: Make sure the winch mounting bolts and winch hardware has been checked for proper torque.**

## **CAUTION**

**Sometimes it may be necessary to remove the cable from the winch drum to install the mounting hardware or roller/hawse fairlead.**

## **Step#4**

Find a location to mount the solenoid box securely. Under the seat, in the storage box, or on a frame rail in the rear will be the best places to choose. Look for a suitable location to install the female plug for the hand controller. We recommend installing this in the front of the ATV by the fender near the shift lever or in the rear of the ATV under the seat. You may have to extend the wires depending on where you install the female plug. See figures 1-4 on following pages.

# Installation Instructions

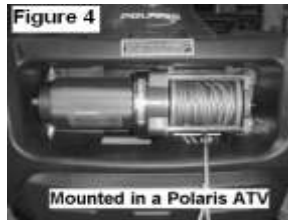

## Step #5

Connect the wiring as shown in Figure 6 and double check each wire connection for correct position. Tie down the wire as needed for a clean look and dependable service.

**When attaching wires to the motor terminals, hold the inner nut with a second wrench to avoid the terminal from rotating in the housing. This will help avoid internal wire breakage. Connect the black wire to the battery last.**

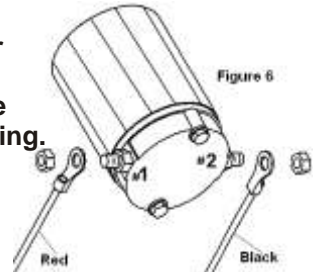

**NOTE:** If the battery is of a type that will not accept the supplied terminals, you may have to find the correct adaptors at a local automotive store.

**Always use the safety hook strap when the hook is near the fairlead or winch drum.**

## Step#6

Before testing the winch, pull & turn the clutch handle to the free position. Always wear heavy gloves when handling heavy wire rope. Pull about 2 feet of wire rope off the winch and place the clutch handle in the engaged position. See Figure 5.



# Installation Instructions

## Step #7

Install the manual hand control for the winch into the female connector, push the rocker switch on the controller one way and then the other to determine that both work correctly. If the winch works in the opposite direction you want the hand control listed in/out or color to represent, just reverse the two wires that connect to the #1 and #2 terminals on the winch motor. See figures 7 & 8.

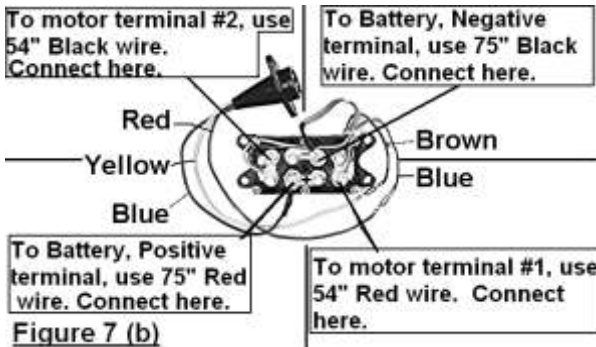
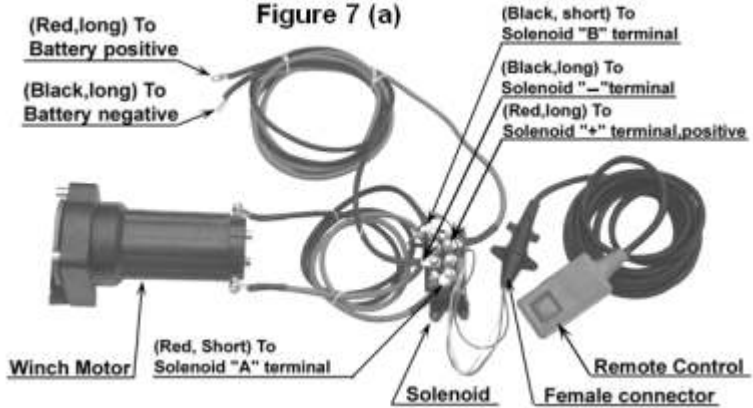

**Figure 7 (b)**

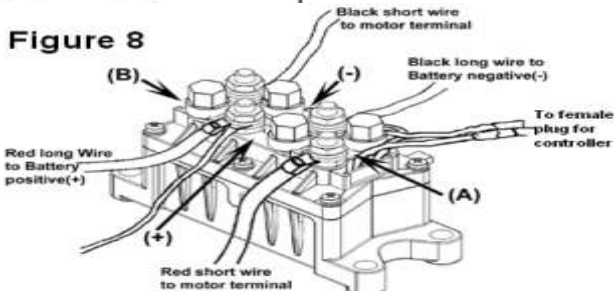

Connect all wiring as shown. If you do not you can burn out the solenoid box on the first attempt to use the winch.

# Winch female connector installation instructions

## Step # 8

Find a suitable spot for the female plug to be installed. Do not drill into the gas tank or any electric wiring. Make certain that you can easily insert the hand controller into the plug where ever you choose to install it before drilling the installation holes.



**When you are running the wire for the electric winch installation, make sure that you avoid mounting wires to anything that gets hot. Also do not mount the wires to anything that moves like the suspension or shifting devices etc, or anywhere the moving parts can touch the installed components.**

**NOTE:** Should the winch show any damage to itself or the wire rope, do not operate it. Call the nearest repair facility or Mile Marker customer service at 1-954-782-0604 ext. # 113.

**NOTE:** Before using the winch, you **MUST** spool out the wire out to the last 5 wraps of the cable on the bare drum. Then apply about 100 lbs of pressure to the winch when spooling the wire back in. You can apply the hand or foot brake slightly to accomplish this.



**Failure to do so will allow the wire on the outer layers of the winch to be pulled through the inner layers & destroy the cable strands in as little as the first use. Cable is not a warranty item.**

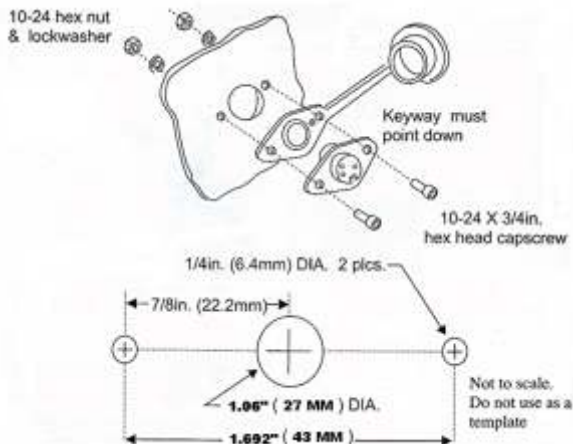

# Winch Operation

## **Clutch Operation:**

The clutch is operated by pulling out the clutch “T” handle and rotating it about 45-90 degrees. See Figure 5. This will allow you to freespool the winch. Turn the “T” handle until it pops back into place & make sure it goes fully in gear.

**CAUTION** Never release the wire rope while under tension. Doing this can badly damage the winch and/or cause property damage and serious injury.

## **Motor Temperature:**

This winch is designed for intermittent use only. Do not run this winch at a high load for an extended period of time. To find a run time while using the winch, stop operation. Secure the load. Release the tension on the cable. Place your hand on the motor to check temperature. If you feel the motor is warm to the touch, let it cool off for a few minutes. 15-20 minutes is usually satisfactory, then feel the motor again to see if it is ok to continue. If the motor is laboring, stop sooner and more often to check the motor temperature. If the winch motor stalls, quickly stop winching and let the motor cool off.

## **Battery Recommendation:**

A fully charged battery will give the best service. One 12 volt DC battery with a minimum of 12 amp hour charging system will work and 150-250 cranking amps.

## **Maintenance:**

No lubrication will be needed or required for the life of the winch. Inspect the wire rope and winch before every use. Check the electric wiring about every few months to insure good, tight connections.

## **Spooling under load:**

Always ensure that wire rope passes between winch drum & mounting surface. Always wind the rope as evenly and tight as possible.

**CAUTION** Avoid shock loading the winch when spooling in. If this is done you can cause a hazardous condition that can break the wire or damage the winch.

Avoid pulling at an angle for an extended period. This will stack the wire up on side of the spool and cause serious damage to the winch. You may have to reposition the wire a few times to allow the winch to pull in a straight line.

## **Rigging:**

Spool out as much wire as possible to the farthest object available. Keep the wire in as straight a line as you can. Pack the line back on the winch as evenly as possible when retrieving the wire rope. Natural anchors like trees, stumps and rocks are the better choices. Always use a tree saver where ever possible. Only connect the wire rope to an object that will be able to resist the pulling power of the winch being used. Using a double line with a snatch block will reduce the load on the winch to about half. The lower the amp load on the winch the longer it will take to heat up the motor. See next page for pulling tips, figure 9.

# Winch Operation

These are some good examples on how to rig the wire rope for pulling. Always pull as straight as possible. Do not connect to anchoring objects that will not withstand the load applied to them. Do not allow the wire rope to gather on one side of the winch. It can damage or break the winch.

## Figure 9

### Pulling with a single line

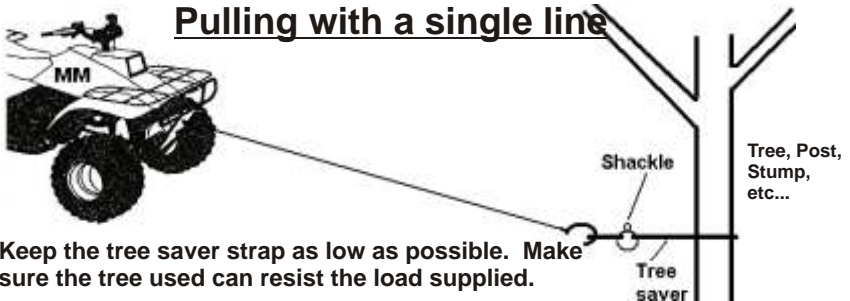

### Using a snatch block with a straight pull

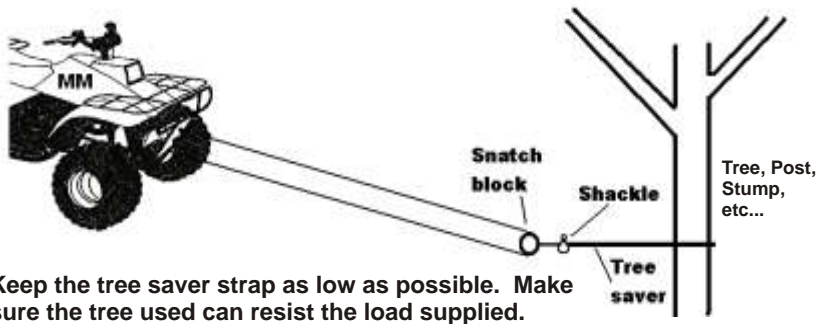

### Change of direction pull

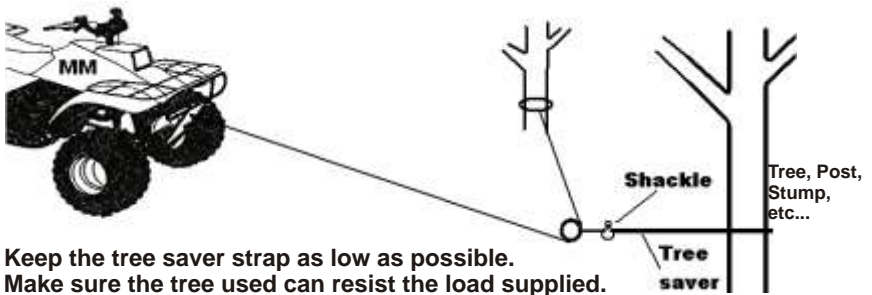

# Winch Parts & Accessories

ITEM	QTY	PART NUMBER	DESCRIPTION	ITEM	QTY	PART NUMBER	DESCRIPTION
1	1	76-50112-01	Motor Assy.	18	2	76-50112-18	Screw M6x12
2	1	76-50112-02	Input Sun Gear Assy.	19	2	76-50112-19	Drum Support Bushing
3	1	76-50112-03	Washer	20	1	76-50112-20	Side Plate
4	1	76-50112-04	Carrier Input Gear	21	2	76-50112-21	Screw M6x10
5	1	76-50112-05	Output Sun Gear	22	1	76-50112-22	Drum
6	1	76-50112-06	Washer	23	1	76-50112-23	Screw M4x10
7	1	76-50112-07	Output Carrier Gear Assy.	24	1	76-50112-24	Cable 7/32" x 50'
8	1	76-50112-08	Bushing	25	1	76-50112-25	Hand Saver Strap
9	1	76-50112-09	Dish Gear	26	1	76-50112-26	Solenoid Pack
10	1	76-50112-10	Clutch Handle	27	1	76-50112-27	Hand Control Switch
11	2	76-50112-11	Bolt M6x30	28	1	76-50112-28	Armature
12	2	76-50112-12	Spring Pin	29	1	76-50112-29	Female Plug
13	6	76-50112-13	Spring Washer D6	30	1	76-50112-30	Hawse Fairlead
14	6	76-50112-14	Washer D6	31	1	76-50112-32	Dust Boot
15	1	76-50112-15	Mounting Frame	32	1	76-50112-33	Magnet Case
16	2	76-50112-16	Tie Bar	33	1	76-50112-34	Brush end Plate
17	1	76-50112-17	Gear Box Cover	34	3 ea.	76-50112-28	Screw M8x30, M8 Nut, D8 Flat Washer, D8 Spring Washer

\*\*\*When ordering parts from this list, make sure to indicate the exact part number for your replacement and that it is from the Winch Parts List\*\*\*

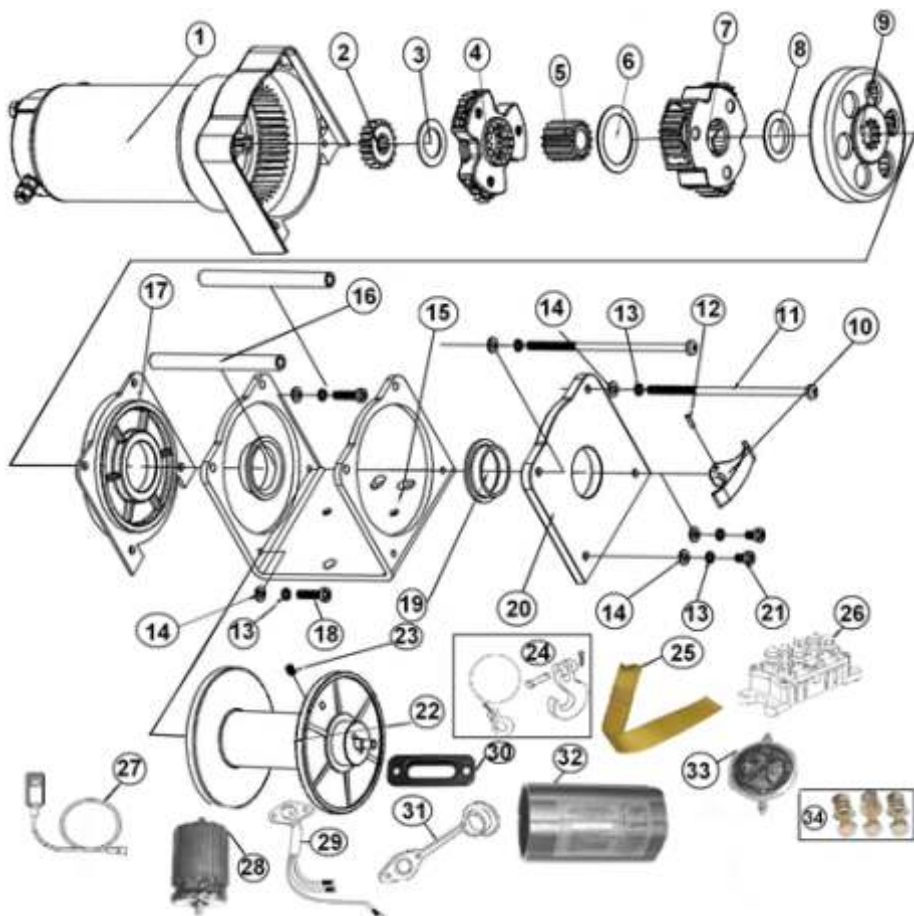

# Troubleshooting Instruction Insert

<u>SYMPTOM</u>	<u>POSSIBLE CAUSE</u>	<u>SUGGESTED REMEDY</u>
Motor does not turn on	-Switch Assy not connected properly	Insert Switch Assy firmly to the connector.
	-Loose battery cable connection	Tighten nuts on cable connectors
	-Solenoid malfunctioning	Tap solenoid to free contact, applying 12 volts to coil terminal directly. Make an audible clicking when activating.
	-Defective Switch Assy	Replace Switch Assy.
	-Defective motor	Check for voltage at armature port with switch pressed. If voltage is present, replace motor.
	-Water has entered motor	Drain and dry. Run in short bursts without load until completely dry.
Motor runs too hot	-Long period of operation	Let winch cool down periodically.
Motor runs slowly or without normal power	-Battery runs down	Recharge battery by running vehicle engine.
	-Insufficient current or voltage	Clean, tighten or replace the connector.
Motor runs but cable drum does not turn	-Clutch not engaged	Push "T" Handle (See Figure 5) into IN position. If that does not work, as a qualified technician to check & repair.
Motor runs in one direction only	-Defective or stuck solenoid	Tap solenoid to free contacts. Repair or replace solenoid.
	-Defective Switch Assy	Replace Switch Assy

### **Warning!**

The Electric Winch is designed for intermittent use only, and should not be used in a constant duty application. The duration of the pulling job should be kept as short as possible. If the Winch motor becomes very hot to touch, stop the Winch and let it cool down for several minutes. Never pull for more than one minute at or near the rated load. Do not maintain power to the Winch if the motor stalls.

# MILE MARKER, INC.

## **LIMITED 2 YEAR WARRANTY ELECTRIC WINCH**

**Mile Marker, Inc.** offers a limited two (2) year warranty (to the original retail purchaser) for each new **Mile Marker consumer/RV** electric winch against manufacturing defects in workmanship and materials on all the mechanical components.

Electrical components consisting of motors, solenoids, wiring, wire connectors and associated parts have a limited one (1) year warranty.

New cable assemblies are warranted against defects in workmanship and materials when received by the retail purchaser. There is no applicable warranty after initial use.

Warranty registration cards for each winch must be submitted at the time of purchase or within 30 days by the end user. Warranty will only be valid for the original purchaser of the winch and installed on the vehicle for which it was originally registered.

**Mile Marker** electric winches are intended for recreational self-recovery usage. The warranty is void if the winch is used in commercial/industrial applications.

The obligation under this warranty, statutory or otherwise, is limited to the replacement or repair at the manufacturer's factory, or at a point designated by the manufacturer, of such part(s) as shall appear to the manufacturer, upon inspection of such part(s) as shall appear to the manufacturer, upon inspection of such part(s), to have been defective in material or workmanship. This warranty does not obligate **Mile Marker, Inc.** to bear the cost of labor or transportation charges in connection with the replacement or repair of defective parts, nor shall it apply to a product upon which repairs or alterations have been made, unless authorized by the manufacturer, or for equipment misused, neglected or improperly installed.

### **IMPORTANT NOTICE:**

**To the fullest extent permitted by applicable law, the following are hereby excluded and disclaimed:**

All warranties of fitness for a particular purpose;

All warranties of merchantability;

All claims for consequential or incidental damages.

**There are no warranties that extend beyond the description that appears on the face hereof.**

Some states do not allow the above exclusions or disclaimers in consumer transactions and as such this disclaimer/exclusion may not apply to you.

To the extent such warranties of fitness or merchantability are deemed to apply to this product, they exist for only so long as the express limited warranty elsewhere set forth is in existence.

**Mile Marker, Inc.** reserves the right to change, alter or improve its products in design, materials or appearance without incurring any obligation to incorporate such changes in products that were previously manufactured.

This Warranty gives you specific legal rights and you may have other legal rights, which vary from state to state.

**To submit a warranty claim contact:**

**MILE MARKER, INC.  
WARRANTY ADMINISTRATOR  
2121 BLOUNT ROAD  
POMPANO BEACH, FL 33069 USA  
PHONE: 1-800-886-8647  
LOCAL PHONE: 1-954-782-0604  
FAX: 1-954-917-3398**



First Name:	
Last Name:	
Age:	
Sex:	
Marital Status:	
Level of Education:	
City/Province:	
Zip/Postal Code:	
Country:	
Telephone Number:	
Email Address:	
Which Mile Marker winch did you purchase?	
Model Number:	
Serial Number:	
Date of Purchase:	
Where did you purchase this product?	
Store or catalog name:	
Store location:	
How satisfied were you with the dealer and/or sales staff?	
Who installed or will install your Mile Marker product?	
Is this the first time you have purchased a winch?	
If no, what brand have you bought before?	
What type of vehicle will this Mile Marker winch be installed on? Is this vehicle two or four wheel drive?	Pickup:
	Year:            Make:            Model:
What is the vehicles main use?	
What other accessories have you purchased for your vehicle?	
Do you belong to any 4-Wheel drive club? Yes or No	If so, what is the Club name:

<b>What factors most influenced the purchase of your Mile Marker product? (Check all that apply)</b>	
<input type="checkbox"/> Mile Marker reputation	<input type="checkbox"/> Price
<input type="checkbox"/> Availability	<input type="checkbox"/> Warranty
<input type="checkbox"/> Previous experience with Mile Marker Inc.	<input type="checkbox"/> Internet
<input type="checkbox"/> Friend/Relative recommendation	<input type="checkbox"/> Advertising
<input type="checkbox"/> Quality/Durability	<input type="checkbox"/> Compatibility with vehicle
<input type="checkbox"/> Salesperson's recommendation	
Salesperson Name: _____	

## Mile Marker Inc. Electric Winch Line



PE 2500



PE 6000



PE 3000



PE 8000



PE 3500



SE 9500



PE 4500



SE 12000

To see a complete product listing, please visit our website,  
<http://www.milemarker.com>