

Electric Winch

Assembly and Operating Instruction Book

Model PE 4500
Part Number 76-50115



Pulling capacity 4500 lb

*

Single Line

*

Power In - Power Out

*

Permanent Magnet DC Motor

*

12 Volt

*

Free Spool



ABUSED WORLD WIDE

2121 Blount Road ♦ Pompano Beach, FL ♦ 33069

Phone (800) 886-8647 (954) 782-0604 ♦ Fax (954) 782-0770

Model PE 4500 P/N 76-50115

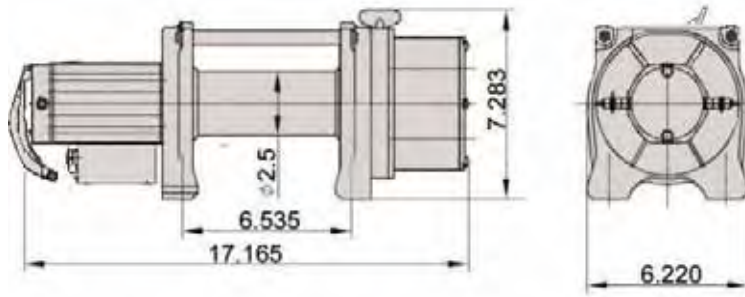

Features:

- Planetary gear system for fast line speed
- Automatic load-holding brake
- Free spooling
- Power In and Power Out
- 1.4 kw (1.9 hp) heavy duty electric permanent magnetic motor
- Low electric current

Specifications:

- Rated line pull.....4500 lbs. (2041 kgs.) Single line
- Gear Reduction ratio...294:1
- Motor.....Permanent magnet 1.4 kw (1.9 hp), 12 volt
- Drum Size.....Diameter 2.5 inches (63mm) x Length 5.512 inches (140 mm)
- Cable supplied.....1/4 inches (6 mm) x 80 ft. (24.5m) aircraft cable (min. break force 7000 lbs.)
- Overall dimension.....(Length x Width x Height) 17.165 in. x 6.2 in. x 7.3 in. (436mm x 1152.4mm x 185mm)
- Net Weight.....51 lb (23 kg)
- Mounting bolt pattern...6.535 inches x 4.5 inches (166 mm x 114.3 mm)

Performance of 1st Layer

<u>Line Pull</u>		<u>Line Speed</u>		<u>Motor Current</u>
<u>lbs</u>	<u>kgs</u>	<u>fpm</u>	<u>mpm</u>	<u>12 V Amp</u>
0	0	14	4.3	35
1500	680	6.6	2	80
2200	998	5.2	1.6	100
3000	1361	4.6	1.4	145
4500	2041	3.3	1	170

Line pull & Cable Capacity by layer

<u>Cable Layer</u>	<u>Rated Line Pull</u>		<u>Cable Capacity</u>	
	<u>lbs</u>	<u>kgs</u>	<u>ft</u>	<u>meters</u>
1	4500	2041	14	4.3
2	3880	1760	31.5	9.6
3	3420	1551	50	15.2
4	3050	1384	70	21.2
5	2750	1247	80	24.5



Safety Warnings & Precautions



When using this winch, safety precautions should always be followed to reduce the risk of personal injury and damage to the winch.

1) LEARN TO USE YOUR MILE MARKER WINCH:

- a. After winch has been installed, take some time and practice using it so you will be familiar with **ALL OPERATIONS**. Periodically check the winch installation to ensure that all bolts are tight.
- b. Maintain your tools with care. Keep all of the tools clean and in good working condition. Before using, check and see if there is any part that appears damaged that may affect proper operation. Any damaged part should be properly repaired and replaced using identical parts by a qualified technician.

2) KEEP WINCHING AREA CLEAR:

Do not allow people to remain in the area during winching operations. Do not step over a taut wire rope or allow anyone else to do so. Direct all personnel to stand clear of any possible pathway the object being pulled could possibly move should a cable break. A snapped cable could cause winch failure, injury or death. Keep proper footing and balance at all times. Do not reach over or across the winch and/or pulling cable while the winch is in operation.

3) INSPECT WIRE ROPE AND EQUIPMENT FREQUENTLY:

The wire rope should be for damage that could reduce it's breaking strength. A frayed rope with broken strands should be replaced immediately. Always replace the rope with a rope that is rated to sustain any load that the winch is capable of pulling. Any substitute must be IDENTICAL in strength, quality, lay and stranding to the Mile Marker cable originally supplied.

4) WORKING AREA CONDITIONS:

Keep the working area well lit. Do not use this winch in the presence of flammable gases or liquids.

5) KEEP CHILDREN AWAY:

Keep children away from working area. Never let children operate the winch.

6) DRESS PROPERLY:

Do not wear loose clothing or jewelry as they can be caught in moving parts. Protective, electrically non-conductive clothes and non-skid footwear is the only type of clothing you should be using when operating the winch. Wear restrictive hair covering to contain long hair.

7) USE LEATHER GLOVES:

When handling or rewinding wire rope always use hand protection to eliminate the possibility of cuts caused by burrs & slivers from broken strands.

8) DRUM ROPE:

Always make sure that there are at least 5 complete turns of rope left on the drum before winching since the rope fastener from broken strands.

9) KEEP HANDS AND FINGERS CLEAR OF WIRE ROPE AND HOOK WHEN OPERATING WINCH:

Never put your finger through the hook when reeling in the last few feet. If your finger should become trapped in the hook or rope, you could lose your finger. Never guide a wire rope under tension onto the drum with your hand.

10) NEVER HOOK THE ROPE BACK ONTO ITSELF:

Holding the rope back onto itself creates an unacceptable strain, breaking individual strands, which in turn weakens the entire wire rope.



Safety Warnings & Precautions Continued



11) KEEP PULLING DURATIONS AS SHORT AS POSSIBLE:

The winch is designed for intermittent use and cannot be used in constant duty applications. Do not pull more than one minute at or near rated load. If the motor becomes too hot to touch, stop and let it cool off for a few minutes. If the motor stalls, cut off the power immediately.

a. DO NOT OVERLOAD: **CAUTION**

Always use this winch at its rated capacity for your safety and for better performance. Do not use inappropriate attachments in an attempt to exceed its rated capacity.

12) AVOID CONTINUOUS PULLS FROM EXTREME ANGLES:

This will cause the rope to pile up at one end of the drum. When possible, please get the rope as straight as possible to the direction of the object.

13) NEVER OPERATE THE WINCH WITHOUT THE ROPE FAIRLEAD FITTED:

Operator injury or winch damage can result if a fairlead is not installed.

14) STAY ALERT: **CAUTION**

Watch what you are doing. Use your common sense. Do not use this winch when you are tired, stressed or **WHEN UNDER THE INFLUENCE OF DRUGS, ALCOHOL OR MEDICATION.**

15) DISCONNECT SWITCH:

Unplug switch when not in use.

16) REPLACEMENT PARTS & ACCESSORIES:

When servicing, use only identical replacement parts. Use of any other parts will void the warranty. Approved accessories are available from your local distributor.



Winch Warnings & Precautions



- 1) Keeps hands and body away from Fairlead (cable intake slot) when operating.
- 2) Secure vehicle in position before using winch.
- 3) Do not exceed winch load weight capacity (see Specifications on Page 1).
- 4) Be certain winch is properly bolted to a structure (or vehicle) that can hold the winch load.
- 5) Always use proper couplings when connecting winch cable hook to load.
- 6) Do not lift items vertically. The winch was designed for horizontal use only.
- 7) Do not overload the winch (see Specifications on page 1). It will do the job better at the load it was intended.
- 8) Do not use inappropriate attachments to extend the length of the winch cable.
- 9) Never lift people or hoist loads over people.
- 10) Never come in between the winch and the load when operating.
- 11) Do not apply load to winch when cable is fully extended. Keep at least **5 full turns** of cable on the reel.
- 12) After moving an item with the winch, secure the item. Do not rely on the winch to hold it for an extended period.



Winch Warnings & Precautions (Continued)



- 13) Examine winch before using. Components may be affected by exposure to everyday weathering, chemicals, salts, and rust.
- 14) Never fully extend cable while under load. Keep **5 complete turns** of cable around the winch drum.
- 15) When loading a boat into a trailer without reel or side hull rollers, make sure the trailer is submerged in the water when the boat is loaded by the winch. Attempting to drag the boat on to the trailer while on land can cause winch failure and possible injury.
- 16) **Never** operate winch if cable shows any signs of weakening, is knotted or kinked.
- 17) Winch does not have a locking mechanism. Secure load after moving.
- 18) Do not cross over or under the cable while it is in process of loading.
- 19) Do not move vehicle with cable extended and attached to load to pull it. The cable could snap.
- 20) Apply blocks (such as a wheel choke) to vehicle when parked on an incline.
- 21) Re-spool cable properly.

Warning

The Electric Winch is designed for intermittent use only, and should not be used in a constant duty application. The duration of the pulling job should be kept as short as possible. If the Winch motor becomes very hot to touch, stop the winch and let it cool down for several minutes. Never pull for more than one minute at or near the rated load. Do not maintain power to the winch if the motor stalls.

UNPACKING

When unpacking, check to make sure all parts are included. Refer to Assembly Drawings and Parts Lists behind. If any part is missing or broken, please call Mile Marker at the number on the cover of this manual as soon as possible.

Installation

STEP 1 Mount electric winch to the vehicle using Cap Screw (37), Nut (34), Flat Washer (35) and Lock washer (36), all provided. If the provided hardware does not accommodate the installation, use SAE grade 8 bolts or higher with torque to 35 ft. lbs. It should be aligned and secured to a solid part or the vehicle (front or rear) where the full rated load will be evenly distributed. Also remember that the winch is designed for horizontal pull, not vertical.

STEP 2 Connect the red (positive) Battery cable from the Solenoid Assembly to the closest screw-down positive (+) terminal to 12-volt battery.



Battery cables should not be drawn taut. Leave slack for some cable movement.

Installation Continued

STEP 3

Connect the black (negative) Battery cable from the Solenoid Assembly to the closest screw-down negative (-) terminal to 12-volt battery.

STEP 4

Test electric winch for proper operation. Refer to the operation selection below.

STEP 5

Winch cable must be rewound onto the drum under a load of at least 500lbs. (If this precaution is not taken, inner wraps will damage winch cable).

Operation

1. Disengage the clutch by moving the Cam Ring (29) to the **OUT** position.
2. Grab the Cable Assembly (4) hook and pull the cable to the desired length, then attach to item being pulled.

CAUTION

Always leave at least 5 turns of cable on the drum. Review winch safety warnings & precautions on pages 2 & 3 before continuing.

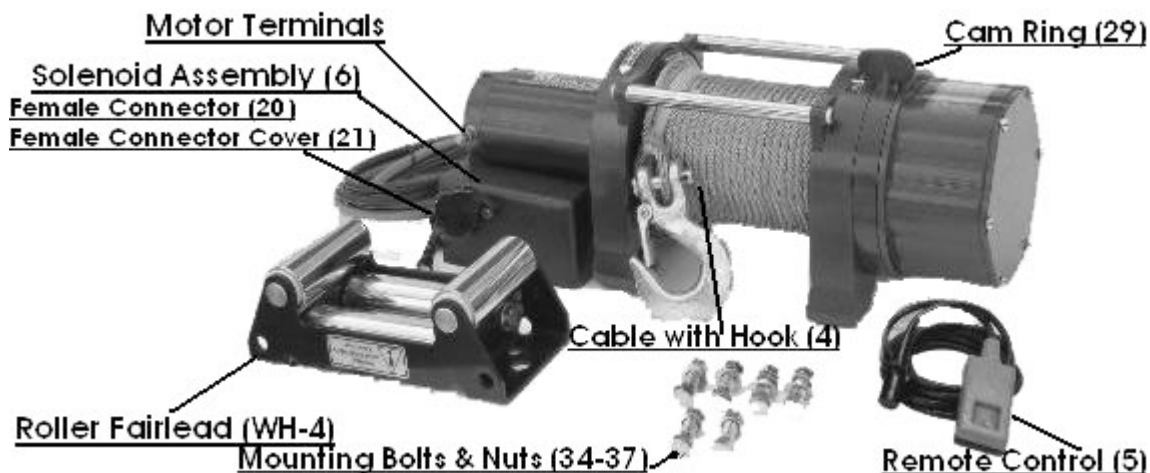

3. Re-engage the clutch by moving the Cam Ring (29) to the IN position.
4. Lift the Female Connector Cover (21) exposing the electrical switch connector.
5. Insert the Switch Assy (5) connector into the Female Connector (20).
6. While standing aside the pulling path, press and hold the Red push button on the Switch Assy (5). Press and hold the opposite push button to reverse directions. Wait until the motor stops before reversing directions.
7. When the pulling is complete, remove the Switch Assy (5) from the Female Connector (20) and replace the Female Connector Cover (21).

CAUTION

- It is important to make sure the winch is mounted on flat surface to guarantee the 3 major sections of the winch (the motor end, the cable drum and the gear housing end) are properly aligned.
- Run the vehicle engine during pulling operations to keep the battery charging.
- When pulling a heavy load, place a blanket or the similar over the cable 5 to 6 feet (1.5m to 1.8m) from the hook.

MAINTENANCE

LUBRICATION:

- 1) All moving parts within Electric Winch having been lubricated using high temperature lithium grease at the factory. No internal lubrication is required.
- 2) Lubricate Cable Assembly (4) periodically using light penetrating oil.

CABLE ASSEMBLY REPLACEMENT:

- 1) Move Cam Ring (29) to **OUT** position.
- 2) Extend Cable Assembly (4) to its full length.
Note how the existing cable is connected to the inside of the drum
- 3) Remove old Cable Assembly and attach new one.
- 4) Retract Cable Assembly onto cable drum being careful not to allow kinking.

TROUBLE SHOOTING		
<u>SYMPTOM</u>	<u>POSSIBLE CAUSE</u>	<u>SUGGESTED REMEDY</u>
Motor does not turn on	-Switch Assy not connected properly	*Insert Switch Assy firmly to the connector.
	-Loose battery cable	*Tighten nuts on cable connectors
	-Solenoid malfunctioning	*Tap solenoid to free contact, applying 12 volts to coil terminal directly. Make an audible clicking when activating.
	-Defective Switch Assy	*Replace Switch Assy.
	-Defective motor	*Check for voltage at armature port with switch pressed. If voltage is present, replace motor.
	-Water has entered motor	*Drain and dry. Run in short bursts without load until completely dry.
Motor runs too hot	-Long period of operation	*Let winch cool down periodically.
Motor runs slowly or without normal power	-Battery runs down	*Recharge battery by running vehicle engine.
	-Insufficient current or voltage	*Clean, tighten or replace the connector.
Motor runs but cable drum does not turn	-Clutch (Cam Ring) not engaged	*Push Cam Ring (29) into IN position. If that does not work, as a qualified technician to check and repair.
Motor runs in one direction only	-Defective or stuck solenoid	*Tap solenoid to free contacts. Repair or replace solenoid.
	-Defective Switch Assy	*Replace Switch Assy

Solenoid Assembly Drawing

With Kill Switch

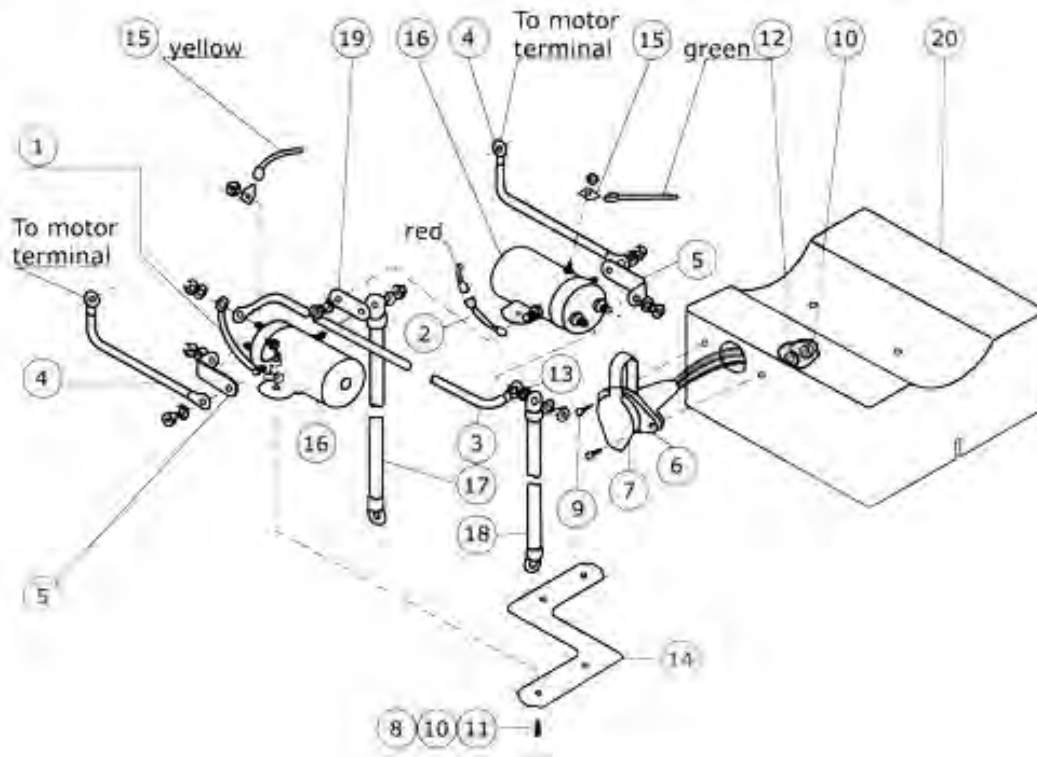

Parts List for Solenoid Assembly

<u>Item #</u>	<u>Description</u>		<u>Quantity</u>
1	Wire Assembly-black	10 Ga x 76 mm	1
2	Wire Assembly-black	16 Ga x 38 mm	1
3	Wire Assembly-black	16 Ga x 89 mm	1
4	Wire Assembly-black	6 Ga x 152 mm	2
5	Strap-copper		1
6	Connector Assy.	Female	1
7	Connector Cover	Female	1
8	Screw	M6 x 12mm	1
9	Screw	M6 x 20mm	1
10	Nut	H x M6	2
11	Washer-Flat		4
12	Lock Washer		6
13	Washer-Shake proof		4
14	Bracket		1
15	Terminal Tab		2
16	Solenoid		1
17	Wire Assy-Battery Red	1.5m	1
18	Wire Assy.-Battery Black	1.5m	2
19	Strap-Copper		1
20	Solenoid Cover		3

Winch Parts List & Assembly Drawing for the PE 4500

ITEM	QTY	PART NUMBER	DESCRIPTION	ITEM	QTY	PART NUMBER	DESCRIPTION
1	1	76-50140-01	Gear Carrier Assy. Input	23	6	76-50140-23	Cap screw M 6 x 19
2	1	76-50140-02	Gear Carrier Assy. Intermediate	24	2	76-50140-24	Brake Shoes
3	1	76-50140-03	Gear Carrier Assy. Output	25	1	76-50140-25	Gear retainer ring
4	1	76-50115-04	Cable Assy. 80ft x 1/4 in.	26	1	76-50115-26	Gear ring
5	1	76-50140-05	Switch Assy.	27	2	76-50115-27	Bolt M6 x 20
6	1	76-50115-06	Solenoid Assy.	28	2	76-50115-28	Spring Washer D6
7	1	76-50115-07	Motor End Bearing Assy.	29	1	76-50140-29	Cam Ring
8	1	76-50115-08	Brake / Shaft Assy.	30	2	76-50115-30	Tie Bar
9	1	76-50115-09	Drum	31	1	76-50140-31	Locking Ring
10	6	76-50140-10	Screw M5 x 12	32	6	76-50140-32	Spring
11	1	76-50115-11	Gear Housing Cover	33	1	76-50115-33	Mounting leg
12	1	76-50115-12	Gasket	34	4	76-50140-34	Nut M 10
13	2	76-50140-13	Drum Bushing	35	6	76-50140-35	Spring Washer D4
14	3	76-50140-14	Thrust Washer	36	1	76-50115-36	Roller Fairlead WH-4
15	1	76-50140-15	Thrust Disc	37	6	76-50140-37	Screw M10 x 34
16	1	76-50140-16	Gear input-sun	***When ordering parts from this list, make sure to indicate the exact part number for your replacement and that it is from the Winch Parts List***			
17	1	76-50115-17	Gear Intermediate Sun				
18	1	76-50140-18	Cap Screw M6 x 10				
19	1	76-50115-19	Cable Anchor				
20	1	76-50140-20	Roll pin D3 x 10				
21	1	76-50140-21	Shaft Bushing				
22	1	76-50140-22	Gear Output-sun				



Roller Fairlead

Specifications	Description
Model	Model WH-4
Cable opening (mm)	105 L x 19 W
Roller Sizes (mm) Vertical	35 D x 87 H
Horizontal	35 D x 119 L
Application (used on)	PE 4500
	PE 6000
Overall dimensions (mm)	212 L x 108 W x 78 H
Weight (kgs)	3.19

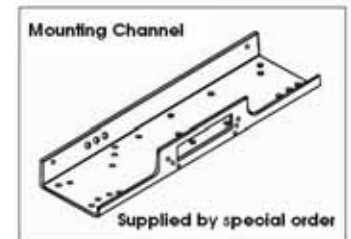
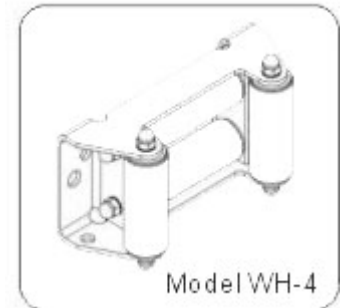
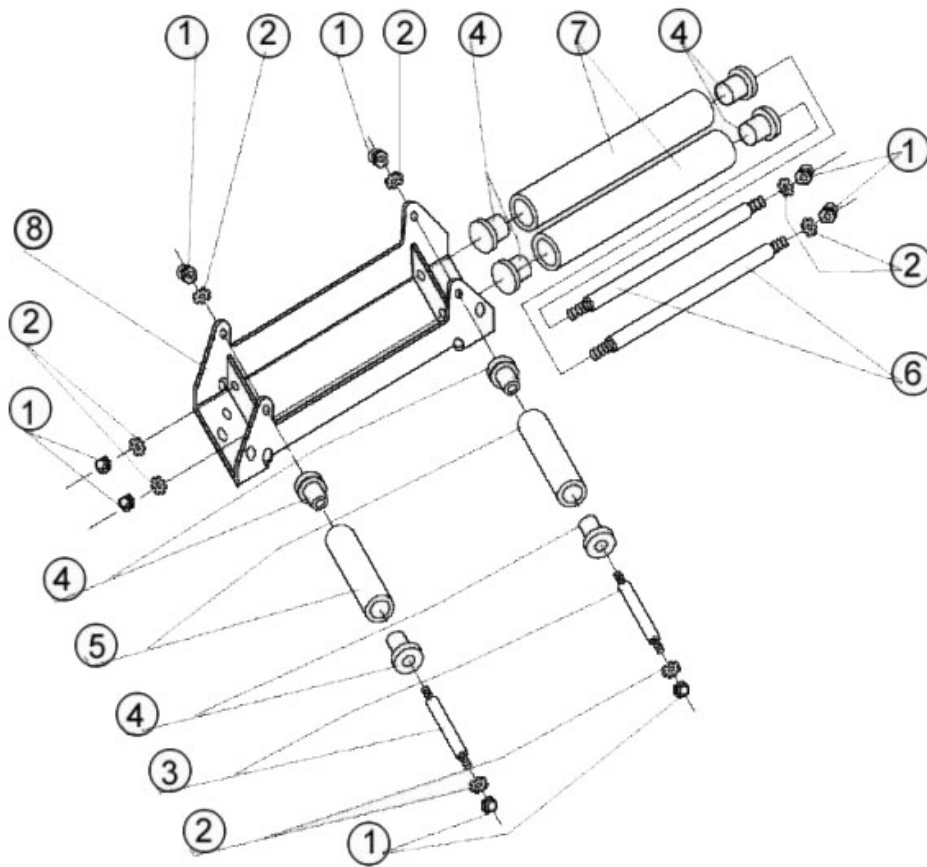

Item Number	Qty.	Description
1	8	Cap Nut
2	8	Star Washer
3	2	Short Shaft
4	2	Nylon Bush
5	2	Short Roller
6	2	Long Shaft
7	2	Long Roller
8	1	Frame

MILE MARKER, INC.

**LIMITED 2 YEAR WARRANTY
ELECTRIC WINCH**

Mile Marker, Inc. offers a limited two (2) year warranty (to the original retail purchaser) for each new **Mile Marker consumer/RV** electric winch against manufacturing defects in workmanship and materials on all the mechanical components.

- Electrical components consisting of motors, solenoids, wiring, wire connectors and associated parts have a limited one (1) year warranty.
- New cable assemblies are warranted against defects in workmanship and materials when received by the retail purchaser. There is no applicable warranty after initial use.

Warranty registration cards for each winch must be submitted at the time of purchase or within 30 days by the end user. Warranty will only be valid for the original purchaser of the winch and installed on the vehicle for which it was originally registered.

Mile Marker electric winches are intended for recreational self-recovery usage. The warranty is void if the winch is used in commercial/industrial applications.

The obligation under this warranty, statutory or otherwise, is limited to the replacement or repair at the manufacturer's factory, or at a point designated by the manufacturer, of such part(s) as shall appear to the manufacturer, upon inspection of such part(s) as shall appear to the manufacturer, upon inspection of such part(s), to have been defective in material or workmanship. This warranty does not obligate **Mile Marker, Inc.** to bear the cost of labor or transportation charges in connection with the replacement or repair of defective parts, nor shall it apply to a product upon which repairs or alterations have been made, unless authorized by the manufacturer, or for equipment misused, neglected or improperly installed.

IMPORTANT NOTICE:

To the fullest extent permitted by applicable law, the following are hereby excluded and disclaimed:

- 1) All warranties of fitness for a particular purpose;
- 2) All warranties of merchantability;
- 3) All claims for consequential or incidental damages.

There are no warranties that extend beyond the description that appears on the face hereof.

Some states do not allow the above exclusions or disclaimers in consumer transactions and as such this disclaimer/exclusion may not apply to you.

To the extent such warranties of fitness or merchantability are deemed to apply to this product, they exist for only so long as the express limited warranty elsewhere set forth is in existence.

Mile Marker, Inc. reserves the right to change, alter or improve its products in design, materials or appearance without incurring any obligation to incorporate such changes in products that were previously manufactured.

This Warranty gives you specific legal rights and you may have other legal rights, which vary from state to state.

To submit a warranty claim contact:

Mile Marker Inc.
Warranty Administrator
2121 Blount Road
Pompano Beach, FL 33069
Toll Free: 1-800-886-8647



2121 Blount Road ♦ Pompano Beach, FL ♦ 33069

Phone (800) 886-8647 (954) 782-0604 ♦ Fax (954) 917-3398 ♦ Email: warranty@milemarker.com

First Name:	
Last Name:	
Age:	
Sex:	
Marital Status:	
Level of Education:	
City/Province:	
Zip/Postal Code:	
Country:	
Telephone Number:	
Email Address:	
Which Mile Marker winch did you	
Model Number:	
Serial Number:	
Date of Purchase:	
Where did you purchase this product?	
Store or catalog name:	
Store location:	
How satisfied were you with the dealer and/or sales staff?	
Who installed or will install your Mile Marker product?	
Is this the first time you have purchased a winch?	
If no, what brand have you bought before?	
What type of vehicle will this Mile Marker winch be installed on? Is this vehicle two or four wheel drive?	Pickup: Year: Make: Model:
What is the vehicles main use?	
What other accessories have you purchased for your vehicle?	

Do you belong to any 4-Wheel drive club? Yes or No	If so, what is the Club name:
--	-------------------------------

What factors most influenced the purchase of your Mile Marker product? (Check all that apply)			
<input type="checkbox"/>	Mile Marker reputation	<input type="checkbox"/>	Price
<input type="checkbox"/>	Previous experience with Mile Marker Inc.	<input type="checkbox"/>	Internet
<input type="checkbox"/>	Friend/Relative recommendation	<input type="checkbox"/>	Advertising
<input type="checkbox"/>	Salesperson's recommendation Salesperson Name: _____		
<input type="checkbox"/>	Compatibility with vehicle	<input type="checkbox"/>	
<input type="checkbox"/>	Quality/Durability		
<input type="checkbox"/>	Warranty		
<input type="checkbox"/>	Availability		

Mile Marker Inc. Electric Winch Line

PE 3000



PE 4500



PE 6000



PE 8000



E 9000



SE 9500



SE 12000



To see all of Mile Marker's Product Lines, please visit our website at: www.milemarker.com