



**ITEM# 109090**  
**3:1 MOBILE OIL PUMP KIT**  
**MANUAL**



Made in China

For technical questions and replacement parts, please call 1-800-556-7885.  
Thank you very much for choosing a Northern Industrial Product! For future reference,  
please complete the owner's record below:

**Model:** \_\_\_\_\_ **Purchase Date:** \_\_\_\_\_

Save the receipt, warranty and these instructions. It is important that you read the entire instruction sheet to become familiar with this product before you begin using it. This machine is designed for certain applications only. It is strongly recommended that this machine is not modified and/or used for any application other than that for which it was designed. If you have any questions relative to a particular application, DO NOT use the machine until you have first contacted your dealer to determine if it can or should be performed on the product. Before using this product, please read the following instructions carefully.

## OIL PUMP MANUAL

Read the following precautions and instructions before you begin assembly or using. Failure to comply with these instructions could result in personal injury or property damage. Keep these instructions in a convenient location for future reference.

### IMPORTANT NOTE:

The warranty will be void if the pump has been altered in any way

### PROFILE

Oil pumps can be used to transfer lubrication oil, waste oil and antifreeze liquids. This manual is applicable to the following pump only, please confirm your pump is included.

### Specification

Compression ratio	3:1
Operating pressure(bar/psi)	5-8/70-115
Maximum pressure(bar/psi)	8/115
Air consumption(L/min Gallon/min)	240/63.5
Capacity(L/min Gallon/min)	12/3.2
Tube diameter(mm/inch)	42/1.65
Suction tube length(mm/inch)	730/28.7
Air inlet connection	1/4" quick plug 1/4" NPT female
Oil delivery connection	Male 1/2"
Max. viscosity oil delivered	SAE 150
Temperature oil delivered	-10~50°C
Noise level(dB)	82

### 3:1 SERIES OIL PUMP EXPLODED VIEW

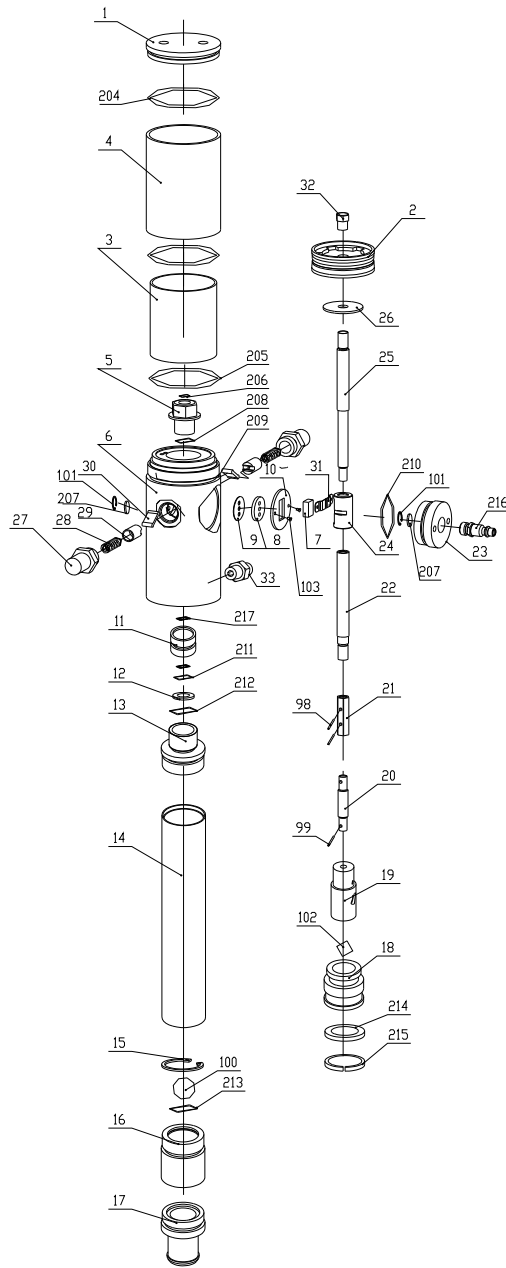

### 3:1 SERIES OIL PUMP PART LIST

#### Appendix

Code	Name	Quantity
1	Air motor cover	1
2	Piston	1
3	Air motor shellinside	1
4	Air motor shelloutside	1
5	Bracket	1
6	Air control center	1
7	Slider	1
8	Gasket	1
9	Soft gasket	1
10	Securing washer	1
11	Bracket	1
12	Washer	1
13	Connect tube	1
14	Suction tube	1
15	Spring circlip	1
16	Valve seat	1
17	Filter or connector	1
18	Piston	1
19	Connecting shell	1
20	Connect shaft	1
21	Connect shell	1
22	Middle shaft	1
23	Air center cover	1
24	Slider shell	1
25	Piston shaft	1
26	Washer	2
27	Spring shell	2

Code	Name	Quantity
28	Spring	2
29	Spring seat	2
30	Trip shoe guide	2
31	Press piece	1
32	Nut	1
33	Outlet	1
98	Pin	2
99	Pin	1
100	Ball	1
101	Small circlip	2
102	Ball	1
103	Screw	2
204	O-ring	1
206	O-ring	2
207	Silencer	2
208	O-ring	1
209	O-ring	1
210	O-ring	1
212	O-ring	1
213	O-ring	1
214	U seal	1
215	Guiding	1
217	OD seal	1
205	O-ring	1
211	O-ring	1
216	Quick coupling	1

#### Troubleshooting

Problem	Possible Causes	Solutions
The pump continues to operate after the gun trigger has been released	<ol style="list-style-type: none"> <li>1. There is a oil leak at some point of the circuit</li> <li>2. Valve sets (part No.11 or 18 and 214, 215) close incorrectly due to dirt or wearing.</li> </ol>	<ol style="list-style-type: none"> <li>1. Check and tighten unions. Repair the leak.</li> <li>2. Substitute damaged elements</li> </ol>
Reduction of the oil delivery. Or reduced pressure in the oil delivery.	<ol style="list-style-type: none"> <li>1. Silencer(207) dirty</li> <li>2. Blocked at some point of the oil circuit</li> <li>3. Ball valve ( 102) closes incorrectly due to dirt or wearing</li> </ol>	<ol style="list-style-type: none"> <li>1. Clean or recharge silencer</li> <li>2. Use clean oil</li> <li>3. Substitute damaged elements</li> </ol>
Air loss through their exhaust	<ol style="list-style-type: none"> <li>1. The sliding valve(7) does not close properly</li> <li>2. Damaged O-ring(204, 205, 206, 208, 209 or 211)</li> <li>3. Damaged piston(2)</li> <li>4. Damaged washer(26)</li> <li>5. Broken spring(28)</li> </ol>	<ol style="list-style-type: none"> <li>1. Disassemble and clean. Substitute in case of damage</li> <li>2. Substitute damaged elements</li> </ol>
Oil leaks through their exhaust	Seal set (11) damaged	Substitute damaged elements

If the pump has anything wrong, please contact dealer or their technical supporter. We don't recommend customers repair the pump themselves.

## STORAGE AND MAINTENANCE

Pumps are delivered in appropriate cardboard boxes. Packaging material should be properly disposed.

Handling and storage of the new pump do not require any special procedures.

However after the pump has been used, empty the used oil in the suction tube into an appropriate container. This is done by overturning the pump.

The dust in compressed air can slow down and even block the motor cylinder. The following steps may prevent this from happening:

- 1) Add 50 grams of appropriate lubricating oil to the air inlet hole weekly; operate the pump for several minutes after adding oil.
- 2) Turn on the pump for several minutes until moving parts are fully lubricated.
- 3) You may repeat the above operation if necessary.
- 4) The above steps should be carried out on a weekly base.

For the pumps that are attached with compressed air treatment equipment, empty the water retained in the reservoir of the filter-purger frequently.

For the pumps that are attached with a lubricator, please pay close attention to the lubricator's oil level and refill with SAE 20, SAE 30 or antifreeze oil for extreme conditions when necessary.

### NOTE:

The user should perform only routine maintenance operations (such as filters, silencers, cleaning...) with the pump in order not to damage it or compromise its safety. Contact our sales or service centers when the pump needs further maintenance.

## GENERAL SAFETY REGULATIONS

When the pump is connected to the compressed air supply:

- The compressed air must be filtered to avoid getting dust and moisture into pump
- The max compressed air pressure must not exceed 0.8Mpa
- To deliver oil, press the knob on the delivery pistol; delivery stops when the knob is released but the whole system remains under pressure.
- Position the pistol so that the circuit can't open accidentally; otherwise oil could leak onto the ground.
- Never point the pistol at people or objects.
- Press the pistol knob.
- Always cut off the air supply after use so that oil can't leak out in case one of the pump's components should break
- Use only original spare parts in case the pump has to be repaired or its components have to be replaced
- Empty all the oil from the pump in case it has to be disposed of.
- When not in use, turn off compressed air to stop pump.
- Do not use the pump near open flames. Do not smoke during this operation.
- Wear oil-proof gloves
- Do not throw the oil away. Used oil has to be disposed of according to national Environmental regulations
- The pumps can be used only to deliver lubricants, used oil or antifreeze liquids. Do not use the pump for any other substance.

## HOW TO USE

### DIRECTLY FIT PUMPS INTO THE DRUM

1. Insert the suction tube of pump into the drum and secure with ring nut, suitable for commercial drums with 57 diameter hole and threading 2" BSP
2. Fit an oil delivery tube for oil outlet of the air-operated pump using only high quality tubes (normally 1/2" or 3/4", according to DIN-SAE norms), by means of 1/2" BSP threading fitting.
3. Oil delivery pistol: Connect delivery tube with delivery pistol using suitable pipe fittings, and point the pistol at right place.
4. Air inlet connection is 1/4" quick plug (or 1/4" NPT female) in all versions. Compressed air connection (to be supplied by the customer) should be done using suitable tubes.
5. A pressure regulator to keep the pump's working pressure at the best possible level (max 70-115 PSI) between the pump and the compressed air line.
6. A cut-off switch can enable the operator to stop the pump at any given moment by cutting the air supply off between the pump and the compressed air line.
7. Turn on all switches.

### WALL INSTALLED

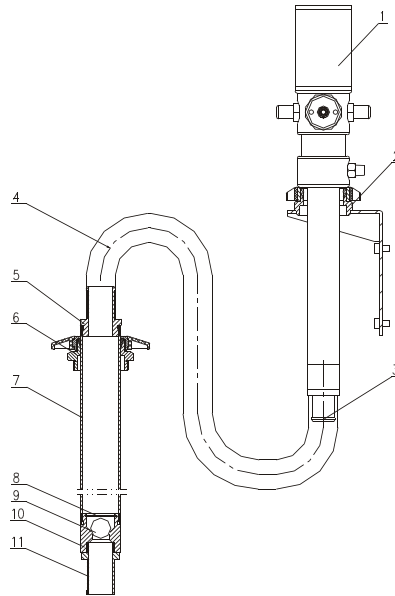

### Parts List

Code	Name	Quantity
1	Oil pump	1
2	Wall bracket	1
3	Pump adapter	1
4	Flexible suction hose	1
5	Suction hose adapter	1
6	Bung adapter	1

Code	Name	Quantity
7	Rigid suction tube	1
8	Spring circlip	1
9	Ball	1
10	Valve seat	1
11	Filter	1

**PROCEED AS FOLLOWS:**

1. Secure the bracket 2 to the wall using the dowels at a height appropriate for the tank's dimensions. Make sure that the wall is solid and thick enough for the dowels. Do not interfere with hydraulic tubes or electric lines.
2. Secure the pump to the bracket.
3. Connect the flexible suction tube 4 to the pump using the clamp provided.
4. Connect the rigid suction 7 to the end of the flexible suction tube 4 using the elastic clamp provided.
5. Put the bung adapter 6 into the drum hole.
6. Put the rigid suction tube 7 into the pump and secure it in place.

**CONNECT THE PUMP WITH OTHER ACCESSORIES:**

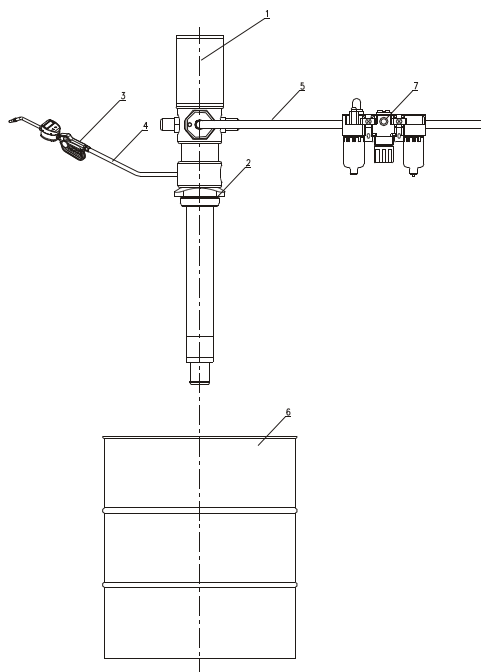

**Parts List**

Code	Name
1	Oil pump
2	Bung adapter
3	Oil pistol
4	Hose with fitting
5	Air hose with quick coupling
6	Drum
7(7-1,7-2,7-3)	Filter, pressure regulator and lubricator

---

## **THE MANUAL OF OIL PUMP DISTRIBUTION KITS**

### **PRESSURE RELIEF PROCEDURE**

To reduce the risk of serious bodily injury, including fluid injection, splashing in the eyes or on the skin, or injury from moving parts, always follow this procedure whenever you shut off the pump, check or service any part of the spray/dispensing system, installing, cleaning or changing spray tips/nozzles, and whenever you stop spraying/dispensing.

1. Shut off the air to the pump.
2. Point the outlet of grease gun into a container and trigger the grease gun to relieve pressure.

### **IMPORTANT NOTES:**

If you suspect that the spray tip/nozzle or hose is completely clogged, or that pressure has not been fully relieved after following the steps above, **VERY SLOWLY** loosen the retaining nut or hose end coupling and relieve pressure gradually, then loosen completely. Now clear the tip/nozzle or hose.

**Drum Application: 20-60kgs/120lbs**

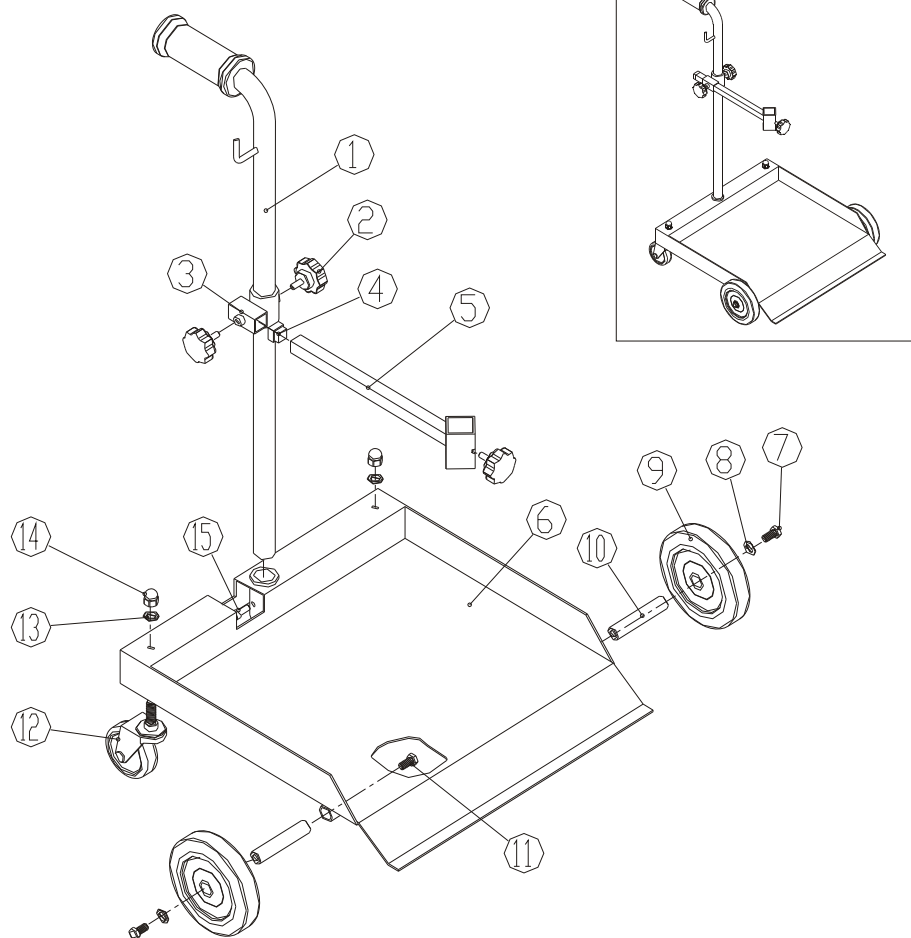

**Parts List**

Code	Name	Quantity
1	Accessories	1
2	Drumholder support	1
3	Handle	1
4	Pumpsupport	2
5	Hexagon set screw	3
6	Stopper	1
7	Accessories support	1
8	Acorn nut	2
9	Washer	2

Code	Name	Quantity
10	Wswiveling wheel	2
11	Hexagon bolt	2
12	Washer	2
13	Wheel	2
14	Axle	2
15	Hexagon bolt	2
16	Trolley top	1
17	Hexagon set screw	2