



OPERATING INSTRUCTIONS TWO STAGE, HI-LOW EXTERNAL GEAR HYDRAULIC PUMPS MODELS 1012, 1053 AND 1056

BARNES OIPM P/N 2690165

**READ CAREFULLY BEFORE ATTEMPTING TO ASSEMBLE, INSTALL, OPERATE OR MAINTAIN THE PRODUCT DESCRIBED. PROTECT YOURSELF AND OTHERS BY OBSERVING ALL SAFETY INFORMATION. FAILURE TO COMPLY WITH INSTRUCTIONS COULD RESULT IN PERSONAL INJURY AND/OR PROPERTY DAMAGE!
RETAIN INSTRUCTIONS FOR FUTURE REFERENCE.**

Description

Our two stage, hi-low, external gear hydraulic pumps, Models 1012, 1053 and 1056, are designed to be direct-driven by gas engines or electric motors. They are suited for use in log splitters and other applications, such as: hydraulic lifts, platform lifts, die tables, automatic hoists, trash compactors, bench presses, machine tool lube systems, filter systems, clamping devices, and transfer systems, etc. They are ideal for press-type applications requiring fast approach/retract speeds and slower peak actuator work speeds because of horsepower limitations or safety constraints.

Unpacking

Due to cast iron construction, very little damage can occur during transit. Do not remove the plastic shipping plugs from the ports until ready for installation. This will keep dirt or foreign material from entering the system.

*See Specification section to determine drive key type and size.

Specifications

Stages	2
Max. Operating Speed	3600 RPM
Construction	Cast Iron
Max. Operating Pressure	3000 PSI
Unload Valve Setting	SEE CHART
Mounting	4 Bolt 4F17
Shaft Extension	1 1/2" (1.50")
Shaft Diameter	1/2" (.50")
Keyed Shaft	Model 1012 – #404 Woodruff Models 1053 & 1056 – .12 square x 1.0"
Inlet Port	Model 1012 3/4", Others 1" dia. tube
Outlet Port	1/2-14 NPTF
Pump Rotation	Clockwise (Facing Shaft)
SEAL KIT	P/N 2300260

CAUTION

These pumps are built for clockwise rotation as viewed from the shaft end of the pump. Gas engine or electric motor must turn the appropriate direction to avoid damage to the pump assembly.

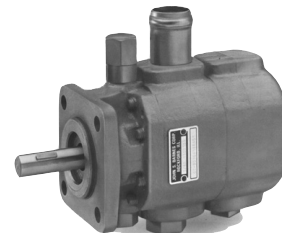

Figure 1

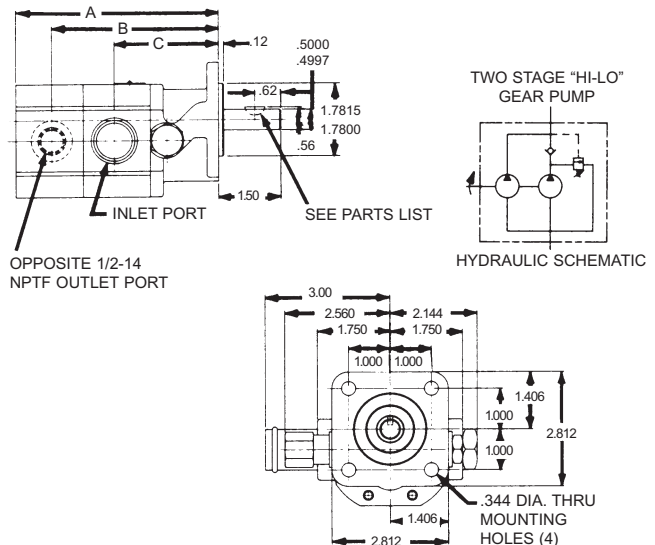

Figure 2 - Dimensions

Performance Characteristics*

		MODEL		
		1012	1053	1056
Minimal Displ. (cu. in./rev.)	1st Stage	.517	.647	.766
	2nd Stage	.129	.194	.258
	Total	.646	.841	1.024
GPM @ 3600 RPM @ 250 PSI	1st Stage	8.06	10.08	11.94
	2nd Stage	3.02	3.02	3.97
	Total	10.07	13.1	15.91
Max. Pressure PSI	1st Stage	500	500	600
	2nd Stage	3000	3000	3000
Min. HP @ 2000 PSI (3500 RPM)		5 HP	5 HP	8 HP

(*) When outlet port pressure is under 450 PSI, both stages are working and total displacement applies. Above 450 PSI, only 2nd stage displacement applies.

Specifications (Continued)

2-Stage, High/Low Pump Dimensions (Tabular)

MODEL	A	B	C
1012	4.906"	4.031"	2.531"
1053	5.468"	4.594"	3.094"
1056	5.468"	4.594"	3.094"

⚠ WARNING! ⚠

General Safety Information

DISCONNECT POWER BEFORE SERVICING THIS EQUIPMENT.

1. Follow all local electrical and safety codes, as well as the National Electrical Code (NEC) and the Occupational Safety and Health Act (OSHA).
2. Never exceed the maximum operating speed and pressure of the pump.
3. If using AC motors, ground the motor properly by wiring with a grounded, metal-clad raceway system, using a separate ground wire connected to bare metal of the motor frame, or other suitable means.
4. Guard all moving parts.

⚠ WARNING! ⚠

RELEASE SYSTEM PRESSURE BEFORE SERVICING THIS EQUIPMENT.

5. Drain all liquids from the system before servicing.
6. Check hoses and connections for security before each use.
7. Periodically check the pump and system components.
8. Provide a means of pressure relief for pumps whose discharge line can be shut off or obstructed.
9. Wear safety glasses at all times when working with pumps.
10. Keep work area clean, uncluttered and properly lighted; replace all unused tools and equipment.
11. Keep visitors at a safe distance from the work area.
12. Make the workshop child-proof with padlocks, master switches, and by removing starter keys.
13. Do not operate an engine in an enclosed area.
14. Do not spill gasoline on hot engine surfaces.
15. Store gasoline only in an approved container.
16. Keep dirty and oily cleaning rags in a tightly closed metal container.
17. Check engine oil level before operating the engine.
18. Familiarize yourself with the controls and emergency shut-down procedures.
19. Never operate the equipment when you are fatigued.
20. All system components pressure ratings should be greater than maximum system pressure.
21. Put safety guards on all moving parts.
22. Keep all guards in place.

Installation

⚠ CAUTION

Do not overtighten fittings and bolts – this can damage the pump.

1. Assemble one coupling half to the engine/motor and tighten the set screw.
2. Assemble the other coupling half loosely to the pump shaft. Note drive key dimensions in Specification section of this manual.

⚠ CAUTION

Do not force coupling onto pump shaft. A snap ring inside pump may be damaged by forcing coupling.

3. Insert the rubber spider into engine/motor coupling half.
4. Bolt the pump and mounting gasket "A" loosely to 4-bolt foot-mounted pump adaptor.
5. Align the shafts to make sure they are on center with each other.

⚠ CAUTION

Misalignment with shafts may result in premature shaft seal failure.

6. Tighten the mounting bolts.
7. Mate the coupling halves together, allowing 1/16" gap between halves.
8. Check shaft alignment again.

⚠ CAUTION

The gap in the coupling halves is to prevent end loading of the pump shaft.

9. Tighten the set screw in the pump coupling half.
10. Remove plastic port protectors from the inlet and outlet ports.
11. Squirt oil into the pump for pre-lubrication for start-up.
12. Turn shaft coupling slowly to ensure proper shaft alignment and coupling installation.
13. Connect inlet line by slipping inlet hose over inlet tube and fasten with hose clamp.

NOTE: A few drops of oil on inlet tube beaded section will help ease the installation.

14. Keep inlet hose short and of adequate size to avoid pump cavitation.

NOTE: Cavitation is recognized by excessive pump noise.

⚠ CAUTION

Provide cooling for the hydraulic oil based on: duty cycle, pressure/flow, ambient temperature, oil and component maximum temperature specifications, and reservoir capacity.

15. Use a 1/2" NPTF, high pressure fitting for the outlet port. Use a good quality pipe joint compound (pipe dope) on all NPTF hydraulic fittings.

⚠ CAUTION

Flush all lines to ensure contaminants have been removed.

Installation (Continued)

⚠ CAUTION

Do not use Teflon tape on NPTF hydraulic fittings.

⚠ CAUTION

Do not overtighten NPTF pressure fitting in pump. This could distort or crack the pump gear housing.

⚠ CAUTION

Never run pump without hydraulic oil.

16. At initial start-up, turn the pump several times by hand to prime the pump.
17. Bleed all air from the system to prevent erratic pump operation.
18. After several cycles, check the reservoir oil level and refill as necessary.

NOTE: When the ambient temperature is below 32°F, allow the pump to operate at low pressure for several minutes to warm the oil in the reservoir.

Operation

1. Check oil level before each use.
2. Follow operating instructions for engine or motor.

⚠ WARNING! ⚠

DO NOT EXCEED THE PRESSURE RATINGS OF THE SYSTEM COMPONENTS. A HYDRAULIC PRESSURE GAUGE IS RECOMMENDED IN THE HYDRAULIC CIRCUIT.

3. The unloading valve is adjustable up to 600 PSI by turning the adjusting screw clockwise.

⚠ CAUTION

Pressure gauge required when adjusting unload valve.

NOTE: Increasing the unloading valve pressure will require increasing the pump drive horsepower. Factory preset, with a 400-900 PSI adjustment range. Maximum recommended loading for 3 HP electric motors and 5 HP engines is 550 PSI.

⚠ CAUTION

If pump has not operated for an extended period of time, manually rotate pump shaft to prime and lubricate pump.

Maintenance

1. Keep the reservoir filled with hydraulic fluid.
NOTE: Use a good quality automatic transmission fluid (ATF) for year round operation.
2. Make frequent inspections of hydraulic oil and change if contaminated.
3. To fill the reservoir with clean oil. Use a clean funnel fitted with a fine mesh wire screen. Do not use a cloth strainer. Most pump failures, valve malfunctions, and short unit life can be traced directly or indirectly to dirt or other foreign material (water, chips, lint, etc.) entering or already in the hydraulic system.
4. Keep the unit clean of dirt and foreign materials.
5. Keep electrical connections clean.

Troubleshooting Chart

SYMPTOM	POSSIBLE CAUSE(S)	CORRECTIVE ACTION
Pump does not develop full pressure	<ol style="list-style-type: none"> 1. System relief valve set too low or leaking 2. Oil temp. is too high 3. Pump is worn out 4. Double acting cylinder piston seals are cut or worn out 	<ol style="list-style-type: none"> 1. Check system relief valve for proper setting with pressure gauge in outlet line 2. Let oil cool below 140°F 3. Replace worn parts or pump 4. Replace or repair cylinder
Motor won't start	<ol style="list-style-type: none"> 1. Loose connection 2. Circuit breaker tripped 3. Voltage drop 4. Seized pump 	<ol style="list-style-type: none"> 1. Check wiring 2. Reset circuit breaker 3. Use heavier gauge wire 4. Replace pump
Will not pump oil (Motor runs but cylinder does not move, or moves slowly)	<ol style="list-style-type: none"> 1. No oil in reservoir 2. Motor operating wrong rotation 3. Oil level low 4. Suction strainer is clogged 5. Double acting cylinder piston seals are cut or worn out 6. Reservoir breather is dirty or clogged 	<ol style="list-style-type: none"> 1. Check oil level, refill 2. Change rotation of prime mover 3. Add oil as needed 4. Clean suction strainer 5. Replace or repair cylinder 6. Clean reservoir breather and reinstall
Pump motor unit is noisy	<ol style="list-style-type: none"> 1. Low oil level 2. Air in system 3. Suction strainer or in-line filter is clogged 	<ol style="list-style-type: none"> 1. Add oil as needed 2. Bleed air from highest fitting in system by loosening fitting very slightly and operating unit until bubbling of air stops, then tighten 3. Clean suction strainer or in-line filter

MODELS 1012, 1053 AND 1056

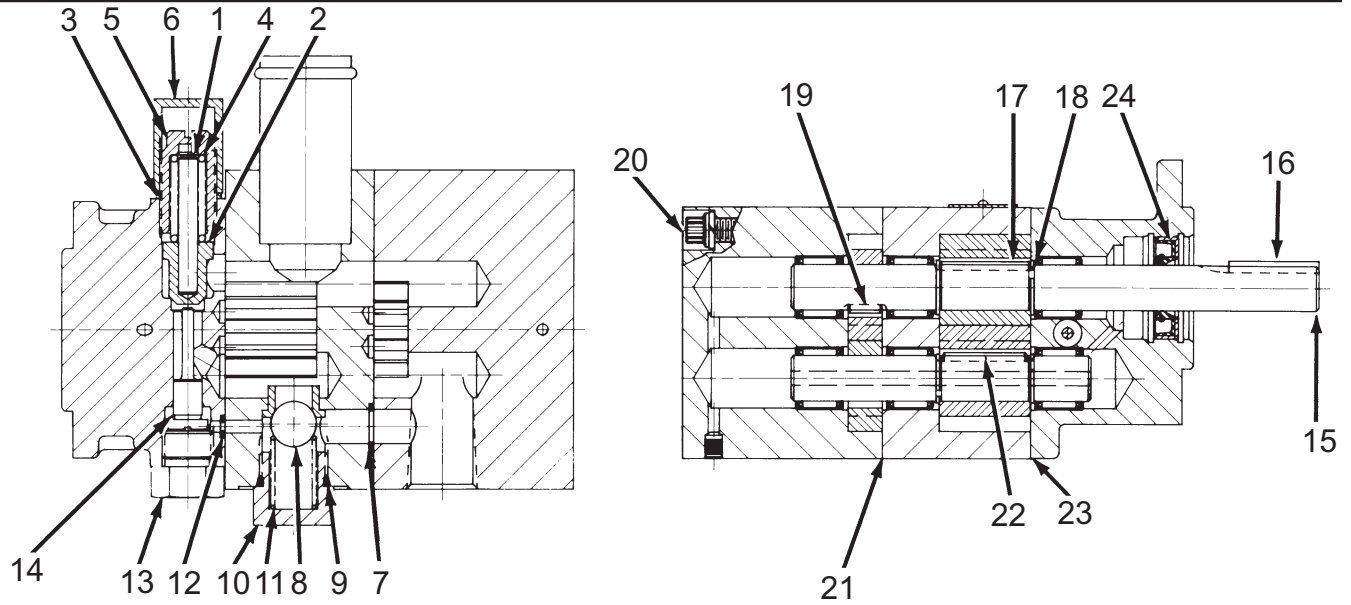

Replacement Parts List

REF. NO.	DESCRIPTION	PART NUMBER FOR MODEL:			QTY.
		1012	1053	1056	
1	Dowel pin	2230031	2230031	2230031	1
2	Plunger	2160206	2160206	2160206	1
3	Copper gasket	2260001	2260001	2260001	1
4	Spring	2110003	2110003	2110003	1
5	Adjustment screw	2130024	2130024	2130024	1
6	Hex cap nut (torqued to 15 # ft.)	2140008	2140008	2140008	1
7	O-ring	2120024	2120024	2120024	1
8	Ball	2870008	2870008	2870008	1
9	O-ring	2120078	2120078	2120078	1
10	Cap	2420088	2420088	2420088	1
11	Spring	2110051	2110051	2110051	1
12	O-ring	2120019	2120019	2120019	1
13	Hex plug	2420106	2420106	2420106	1
14	Valve stem	2160009	2160009	2160009	1
15	Drive shaft	2350177	2350678	2350679	1
16	Drive key	2250013	2250011	2250011	1
17	Gear key	2250013	2250013	2250013	1
18	Snap ring 0.50	2240013	2240013	2240013	4
19	Gear key	2250020	2250020	2250013	1
20	† Assembly screws (1/4-20)	2130078	2130080	2130080	8
21	‡ Gasket kit	2300480	2300480	2300480	1
22	Drive pin	2230021	2230021	2230021	1
23	‡ Gasket kit	2300481	2300481	2300481	1
24	Shaft seal	2120104	2120104	2120104	1
D	<u>Required for mounting</u>				
D	5/16-18 x 3/4 Grade 5 mounting bolts	2130107	2130107	2130107	4
D	4-Bolt mounting gasket	2260064	2260064	2260064	1
D	5/16 Lockwasher for mounting bolts	2150042	2150042	2150042	4

† Screws for item #20 (Grade 8 socket head screws are acceptable)

‡ Gaskets are color coded to maintain specific gear clearances in pump

D Not shown